

Modbus Multiplexer

SGW1-IA2-MMP

User's Manual

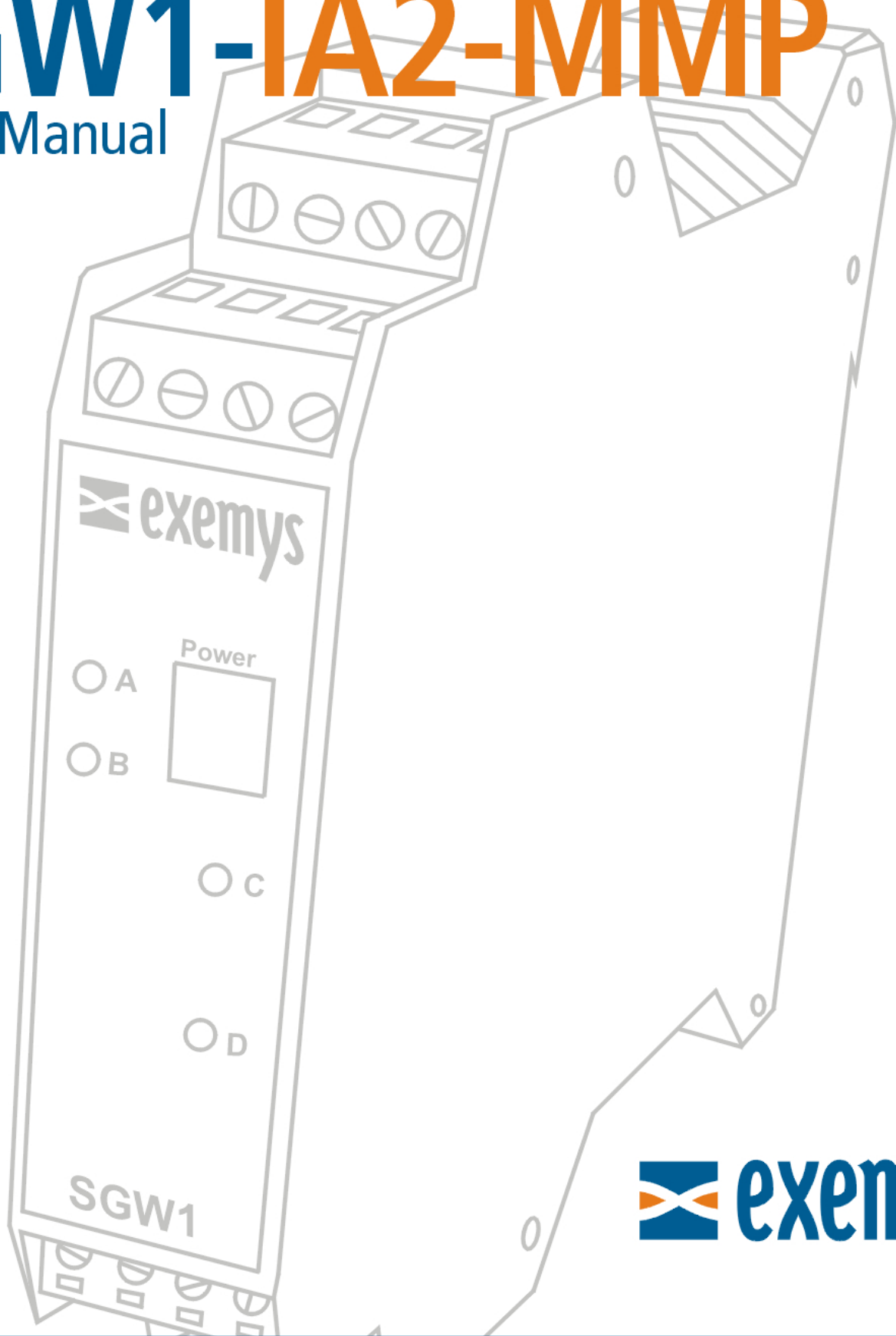

ISO 9001:2000



Exemys Products are in constant evolution to satisfy our customer's needs.
For that reason, the specifications and capabilities are subject to change without prior notice.
Updated information can be found at www.exemys.com

Copyright © Exemys, 2006 All Rights Reserved.
Rev. 2.0.1

Table of Contents

INTRODUCTION	5
1.1 Purpose of the manual	5
1.2 Conventions, terms and acronyms	5
1.3 Product Description	6
INSTALLATION	7
2.1 Power Connection	7
2.2 Serial Ports Connection	7
2.3 Indicator Leds	8
CONFIGURATION	9
3.1 Command Console	9
3.2 Serial Ports Configuration	10
3.3 Pin de control RTS	11
3.4 Master / Slave port configuration	11
3.5 Serial slave port configuration	14
3.6 Slave's range configuration	15
3.7 Master's configuration	15
3.8 Other configuration parameters	16
TECHNICAL SPECIFICATIONS	16
MOUNTING	17

Tables

Table 1 - Acronyms	5
Table 2 - Conventions	5
Table 3 - Serial Ports Configuration	10
Table 4 - Serial slave port configuration	15
Table 5 - Slave's range configuration	15
Table 6 - Master's configuration	15
Table 7 - Other configuration parameters	16

Figures

Figure 1 - Models	6
Figure 2 - Power Connection	7
Figure 3 - Serial Ports Connection	8
Figure 4 - Indicator Leds	8
Figure 5 – DIN rail Mounting	17

Chapter 1

Introduction

1.1 Purpose of the manual

The purpose of this manual is to provide instructions for a fast and simple installation and operation of SGW1-IA2-MMP .

The manual starts with the product description and then provides instructions for proper installation of its hardware. Later on, it includes detailed information on SGW1-IA2-MMP configuration and operation.

This manual is valid for firmware's V1.4 or later.

1.2 Conventions, terms and acronyms

The acronyms used in this manual are listed in the following chart:

Table 1 - Acronyms

Acronym	Description
Bps	Bits per second
PC	Personal Computer
GND	Ground (Reference)
Led	Light Emission Diode

The conventions listed below are used in this manual:

Table 2 - Conventions

Convention	Description
A B C	A set of possible values for command parameters. You can type A, B or C.
n..m	A range of possible values. You can type any value in the range including n and m.

1.3 Product Description

SGW1-IA2-MMP is a serial Modbus communications multiplexer. It allows you to connect up to 3 Modbus ASCII/RTU masters to one or more slaves.

SGW1-IA2-MMP buffers the master's polls giving them priorities, depending which of them came first, and then sends them to the slaves.

There are several models of SGW1-IA2-MMP with different serial ports. Available models are:

SGW1-310-00-IA2-MMP

3 RS232 ports
1 RS485 port

SGW1-400-00-IA2-MMP

4 RS232 ports

SGW1-130-00-IA2-MMP

1 RS232 port
3 RS485 ports

Figure 1 - Models

Each serial port can be configured with a different baud rate, parity and Modbus protocol (ASCII or RTU). So it is also possible to use SGW1-IA2-MMP as a converter.

Chapter 2

Installation

2.1 Power Connection

SGW1-IA2-MMP accepts an input voltage range of 10 to 30 Vdc.

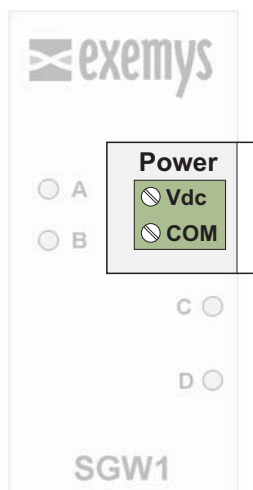

Figure 2 - Power Connection

2.2 Serial Ports Connection

SGW1-IA2-MMP supplies 4 serial ports, named COM A, COM B, COM C y COM D, to which you can connect Modbus devices. These can be either Slaves or Masters

By default, the COM B is used to connect the slave and COMs A, C and D are used to connect the masters.

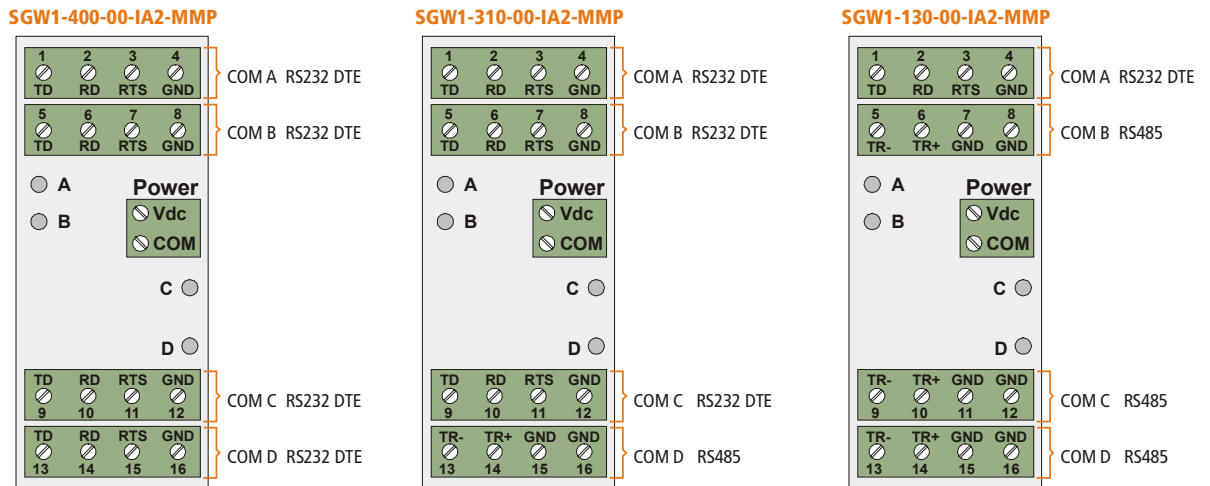

Figure 3 - Serial Ports Connection

2.3 Indicator Leds

SGW1-IA2-MMP features two indicator LEDs: green and yellow.
 If the yellow LED blinks it means the SGW1-IA2-MMP is sending data to the slaves.
 If the green LED blinks it means the SGW1-IA2-MMP is receiving data from the slaves.

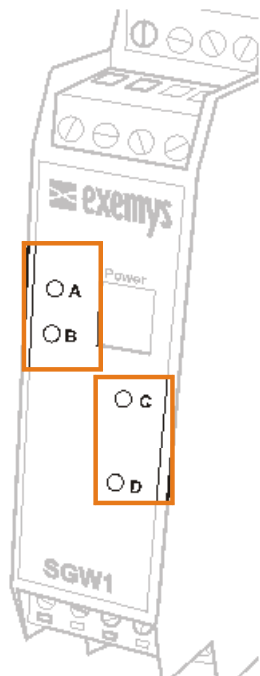

Figure 4 - Indicator Leds

Chapter 3

Configuration

3.1 Command Console

The device can be configured through a serial command console over serial port COM A. You have to connect SGW1-IA2-MMP to a RS-232 port of a PC. To such effect, you must have a serial terminal program (Windows HyperTerminal or the like).



The communications program must be set as follows:

Baud rate:	9600 bps
Parity:	None
Data bits:	8
Stop bits:	1
Flow control:	None (9600,N,8,1).

You can enter the configuration mode through the serial port:

- Connect SGW1-IA2-MMP to a PC and configure the terminal emulation program to 9600,N,8,1.
- Turn on SGW1-IA2-MMP. During the first 7 seconds SGW1-IA2-MMP will wait for the **CFG** command.

- Type **CFG** and press ENTER. The SGW1-IA2-MMP will display a welcome message to the configuration command console.

IMPORTANT

After configuring the device use the command **END**.

```
SGW1-IA2-MMP Modbus Multiplexer - Exemys (V1.4):
-----
>
```

3.2 Serial Ports Configuration

Serial port's configuration parameters are:

- **Baud Rate:** Serial Port rate of transference by bits per second. Possible values are: 1200, 2400, 4800, 9600, 14400, 19200, 28800, 38400, 57600 and 115200
- **Parity:** parity type. Possible Values are: NONE (without parity), EVEN (Even parity) and ODD (Odd parity).
- **Protocol or Format:** You may select Modbus/ASCII or Modbus/RTU. When you select Modbus/RTU the serial transmission pattern will be of 8 bits. If you select Modbus/ASCII, data bits will be 7. If you select Modbus/ASCII 8 bits, data bits will be 8.
- **Packet Timeout (only for Modbus/RTU):** Modbus/RTU packets are divided by time periods. This parameter allows to change the maximum time, to be calculated after the reception of the last byte of the packet, during which SGW1-IA2-MMP will presume that such packet has not yet finished to arrive. After the lapse of the maximum time period, SGW1-IA2-MMP will presume the packet has finished its arrival. The packet timeout is calculated as units of time of a byte, being the minimum of 3 bytes.

Use the following commands to configure SGW1-IA2-MMP's serial ports.

Note: values on **bold** are factory defaults.

Table 3 - Serial Ports Configuration

Command	Description
BAUDx: (Baud_rate)	Configures the COM X rate of transference by bits per second. Possible values are 1200, 2400, 4800, 9600 , 14400, 19200, 28800, 38400, 57600 or 115200.
PARITYx: (N E O)	Configures COM X parity N = NONE E = EVEN O = ODD

PROTOCOLx: (R A 8)	Selects between Modbus/ASCII and Modbus/RTU in COM X R = Modbus/RTU A = Modbus/ASCII 8 = Modbus/ASCII 8 bits
PKTTOUTx: (3..50)	Modbus/RTU Packet Timeout in COM X (4)

3.3 Pin de control RTS

The SGW1-IA2-MMP can use the RTS pin to activate external devices, for example, a radio modem.

The RTS pin can have a fixed value or it can be timed. When timed, the RTS pin will be activated for some time before sending data and will deactivate some time after sending data. This option applies to all RS232 ports.

Table 1 - Pin de control RTS

Comando	Descripción
RTSMODE: (0 1)	Operating mode. 0 =Fixed 1 = Timed
RTSDON: (0...1000)	Delay before sending data (50)
RTSDOFF: (0...1000)	Delay after sending data (50)
RTSLOGIC: (0 1)	RTS polarity. 0 = Inverted 1 = normal

3.4 Master / Slave port configuration

- **Master/Slave COM:**
This command specifies whether you will connect a Master or a Slave device to each port.

Command	Description
MSCOM: (m s) (m s) (m s) (m s)	Configures if a Master or a Slave will be connected to the COM m = a Master will be connected to this COM s = a Slave will be connected to this COM

When this command is applied, the slave's range configuration will reset. Ranges vary depending on the number of COMs configured as Slaves.

▪ **Examples:**

1. Connect Masters to COMs A & B, and Slaves to COMs C & D

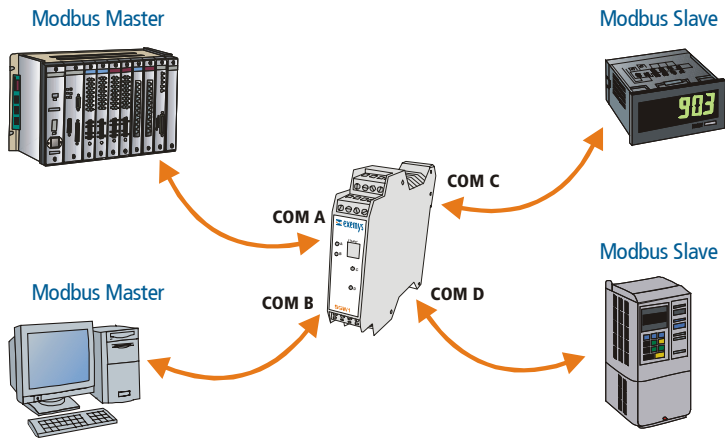

```
>MSCOM:mmss
OK, Device connected is: (COM A) Master
OK, Device connected is: (COM B) Master
OK, Device connected is: (COM C) Slave
OK, Device connected is: (COM D) Slave
OK, Ranges Deleted
```

Master	First	Last	Slave
A	1	100	C
A	101	247	D
B	1	100	C
B	101	247	D

2. Connect Master to COM C, and Slaves to COMs A, B & D

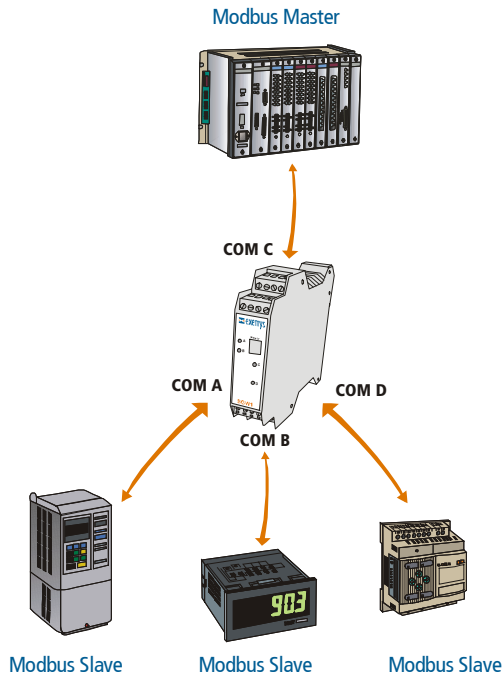

```
>MSCOM:ssms
OK, Device connected is: (COM A) Slave
OK, Device connected is: (COM B) Slave
OK, Device connected is: (COM C) Master
OK, Device connected is: (COM D) Slave
OK, Ranges Deleted
```

Master	First	Last	Slave
C	1	85	A
C	86	170	B
C	171	247	D

3. Connect Masters to COMs B, C y D, and Slave/s to COM A

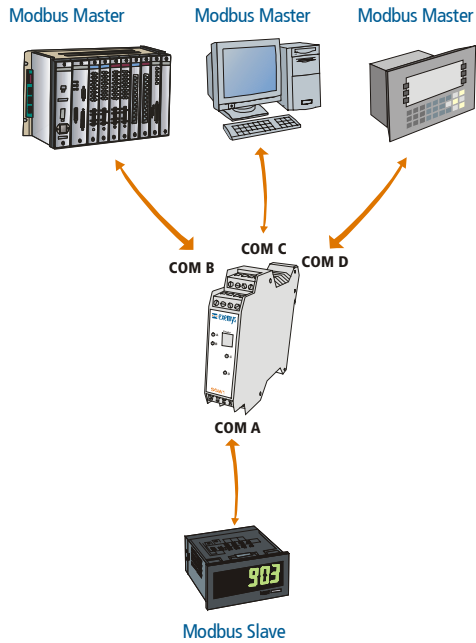

```
>MSCOM:smmm
OK, Device connected is: (COM A) Slave
OK, Device connected is: (COM B) Master
OK, Device connected is: (COM C) Master
OK, Device connected is: (COM D) Master
OK, Ranges Deleted
```

Master	First	Last	Slave
B	1	247	A
C	1	247	A
D	1	247	A

3.5 Serial slave port configuration

- **Slave's time out:**
Each time SGW1-IA2-MMP sends a message to a slave it waits for an answer. If the slave takes longer than this time it will go ahead with the next master.

Table 4 - Serial slave port configuration

Command	Description
SLVTOUT: (50..1000)	Changes slave's answer time out (all COMs). Expressed in milliseconds. (50)
SLVTOUTx: (50..1000)	Changes slave's answer time out. (COMx) Expressed in milliseconds. (50)

3.6 Slave's range configuration

- It's possible to limit which slaves each master can poll. If a master tries to poll an invalid slave the poll is ignored. It's possible to configure up to 32 slaves ranges.

Table 5 - Slave's range configuration

Command	Description
SRANGEADD: (A B C D), (1..247), (1..247), (A B C D)	Adds a slave's range to the master. (A B C D): the port to which the Master is connected (1... 247): range's lower limit (1... 247): range's upper limit (A B C D): the port to which the Slave is connected
SRANGEDEL: (A B C D), (1..247), (1..247), (A B C D)	Deletes a slave's range to the master.
SRANGELIST	Lists a the slave's ranges.

- Example**
Allow master A to talk to slaves 1 to 20, that are connected to port B, and to slaves 35 to 39, that are connected in port C.

```
SRANGEADD:A,1,20,B
SRANGEADD:A,35,39,C
```

3.7 Master's configuration

- Priority:**
Each master can have a different priority level. 0 is the highest priority. The device is going to wait 10 extras milliseconds to answer to the master per priority step.

Table 6 - Master's configuration

Command	Description
PRIORITYx: (0..100)	Master X's priority level. (0)

3.8 Other configuration parameters

Table 7 - Other configuration parameters

Comando	Descripción
HELP	Lists all available commands with their syntax and a descriptive text.
LIST	Shows SGW1-IA2-MMP configuration
FACTRESET	Resets to default configuration
END	Ends configuratio mode and switches to RUN mode.

Technical Specifications

- **Serial Protocols:** Modbus RTU / ASCII / ASCII 8 bits.
- **Serial Interface:** 4 serial ports on 4 terminal block connectors .
- **Devices Supported:** Any Modbus RS232/RS485 serial port device.
- **Baud Rates:** 1200, 2400, 4800. 9600, 14400, 19200, 28800, 38400, 57600, 115200
- **Modbus Masters:** Up to 3.
- **Modbus Slaves:** Up to 3.
- **Management:** RS232 serial console.
- **Indicators:** Data to slave.
Data from slave.
- **Dimension / Weight:** 4.49 x 3.94 x 0.89 in. (HxWxL).
(114 x 100 x 22.5 mm).
0.31 Lbs (0.140 Kg).
- **Power Supply:** 10 a 30 Volts DC.
200mA max.
- **Enviromental:** Operating temperature: 23 to 149 °F (-5 to 65 °C).
Storage temperature: -40 to 167 °F (-40 to 75 °C).
- **Optional Accessories:** Programming cable.
- **Warranty / Support:** 1-year limited warranty. Technical Support included.

Mounting

El SGW1-A2-MMP can be mounted on a DIN rail.

To mount the device to the DIN rail (as shown in figure 5), tip the upper part of the device towards the rail and place the slot on the edge of the rail (A). Press firmly the device towards the rail until it is fixed. You'll hear it click when it is done (B).

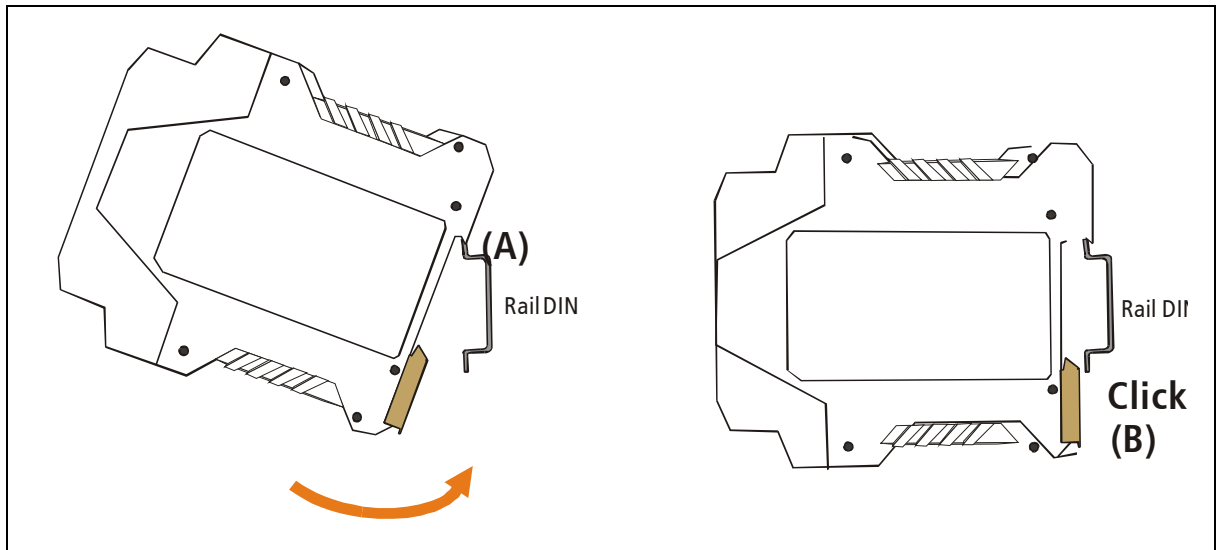

Figure 5 – DIN rail Mounting

To detach the device off the DIN rail (figure 6), pull downwards the device's metallic clip (C) and then remove from rail.

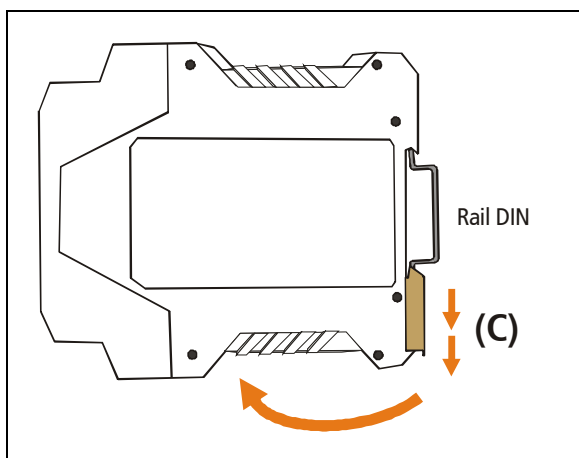

Figure 6 – Detaching the device