

MODBUS REMOTE I/O

RMS1-GR

User's Manual

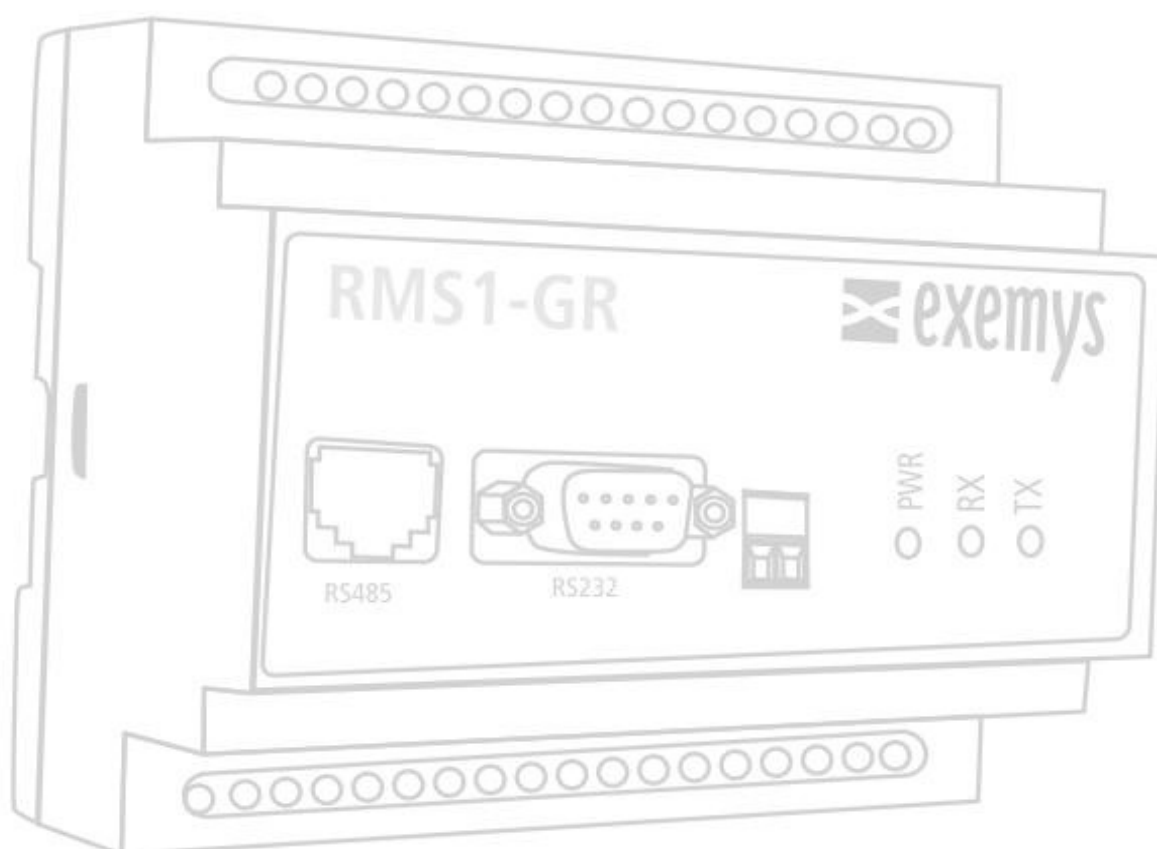

www.exemys.com



The Exemys products are in permanent evolution to satisfy the needs of our clients. For this reason, specifications and capabilities are subject to change without previous notice.

Please find updated information at www.exemys.com

Copyright © Exemys, 2008. All Rights Reserved.
Rev. 6

Contents

1	Introduction	4
1.1	Purpose of this manual.....	4
1.2	Conventions, terms and abbreviations	4
1.3	General Description of the Product	4
1.4	Power Supply	6
1.5	Serial Port Connection	7
1.5.1	RS-232 Connection	7
1.5.2	RS-485 Connection	7
1.6	LED Indicators.....	8
2	Models	10
.1	Models.....	10
3	Serial Configuration	11
3.1	General Description	11
3.2	Screens and Configuration Menus	11
4	Modbus Map	14
4.1	Description of the Modbus Map.....	14
5	Modbus master	16
6	Pin out	18
6.1	Abbreviations and definitions	18
6.2	Inputs/outputs groups.....	18
6.3	Pin out of existing models	18
A	Technical Specifications	21
1.	Power Consumption.....	21
2.	Digital inputs	21
3.	Digital outputs	22
4.	Digital output to drive a relay.....	23
5.	The relay outputs	23
6.	Analog inputs	24
7.	RS485 Connection.....	31

Chapter 1

1 Introduction

1.1 Purpose of this manual

The purpose of this manual is to provide the instructions to simply and quickly install and operate the RMS1 – GR equipment.

The manual begins with a general description of the product followed by the instructions for a correct hardware installation. Its configuration and operation of the device are later described in detail.

1.2 Conventions, terms and abbreviations

Abbreviation	Description
ASCII	American Standard Code for Information Interchange
RTU	Remote Terminal Unit
GND	Ground (Reference to tension)

1.3 General Description of the Product

The RMS1-GR is a device for the acquisition and control of digital and analog inputs and outputs, by means of the Modbus Slave Serial ASCII/RTU.

The equipment has up to 16 opto-isolated or transistor inputs, up to 16 transistor or relay outputs and up to 6 analog inputs (0-10V / 4-20mA), all according to the different models of equipment.

The serial communication is made by means of an RS232 or RS485 serial port.

By means of a device or Modbus Master software, it is possible to obtain the status of inputs and modify the status of outputs, individually or in groups.

Connecting two RMS1-RM you can create I/O tunnels.

Summing up the features of the equipment are:

- Up to 16 digital inputs, opto-isolated or transistor
- Up to 16 digital outputs, transistor or with relay
- Up to 6 analog inputs (0-10V)
- 1 RS232 / RS485 serial Port
- Modbus Slave communications protocol ASCII or RTU

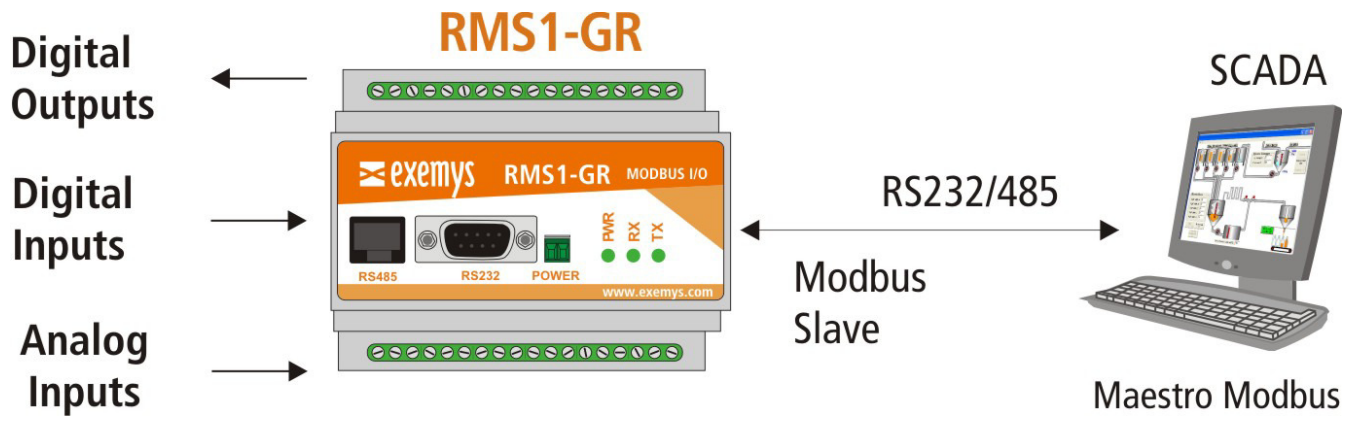

1.4 Power Supply

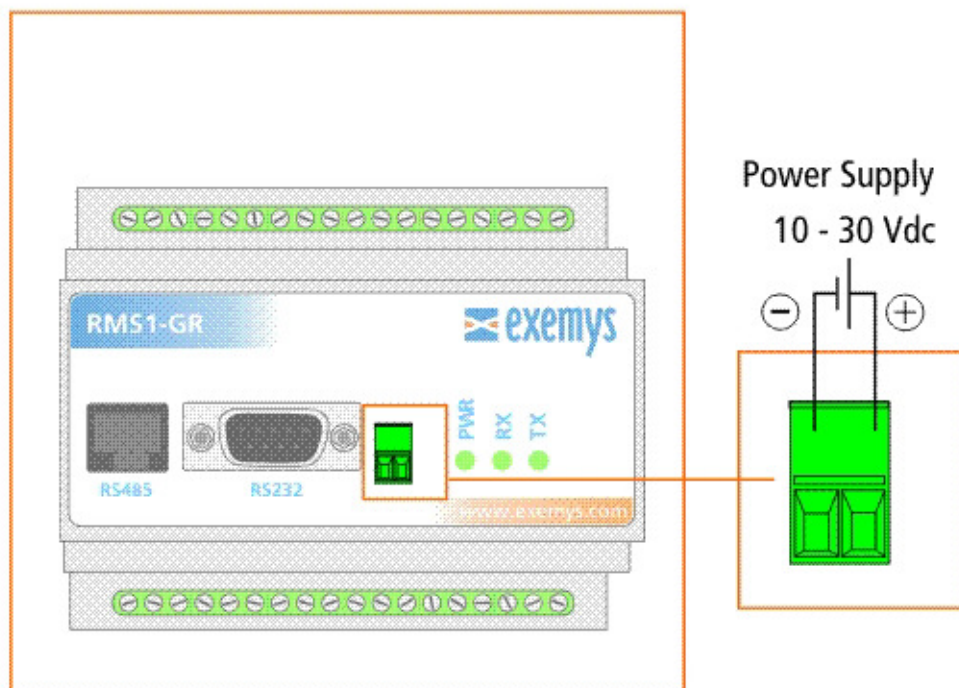

Figure 1 - Power Supply Terminals

1.5 Serial Port Connection

The RMS1-GR has an RS232 serial port in a DB9 connector or an RS485 serial port in a RJ45 connector.

Important Note: Only one port at a time can be used and not simultaneously.

1.5.1 RS-232 Connection

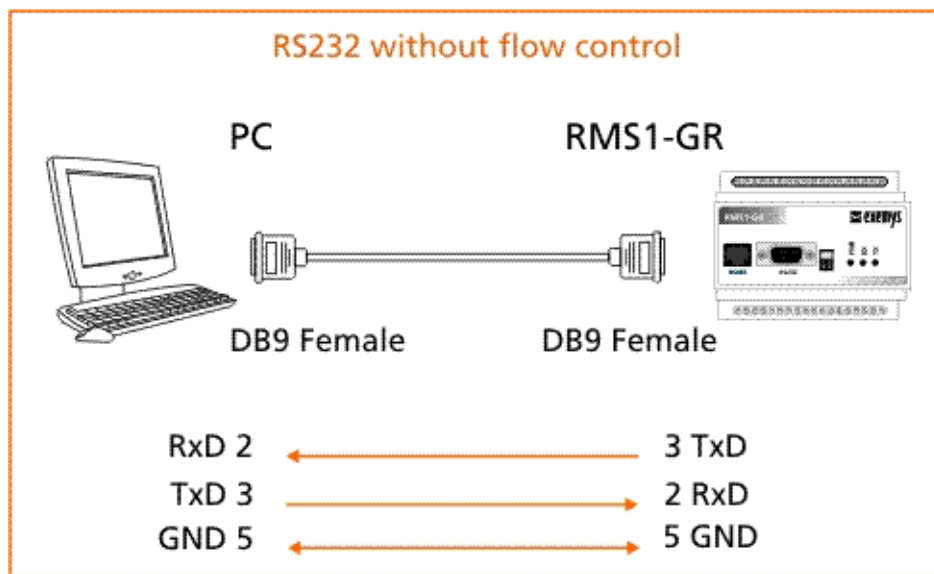

Figure 2 –RS232 serial connection cable

1.5.2 RS-485 Connection

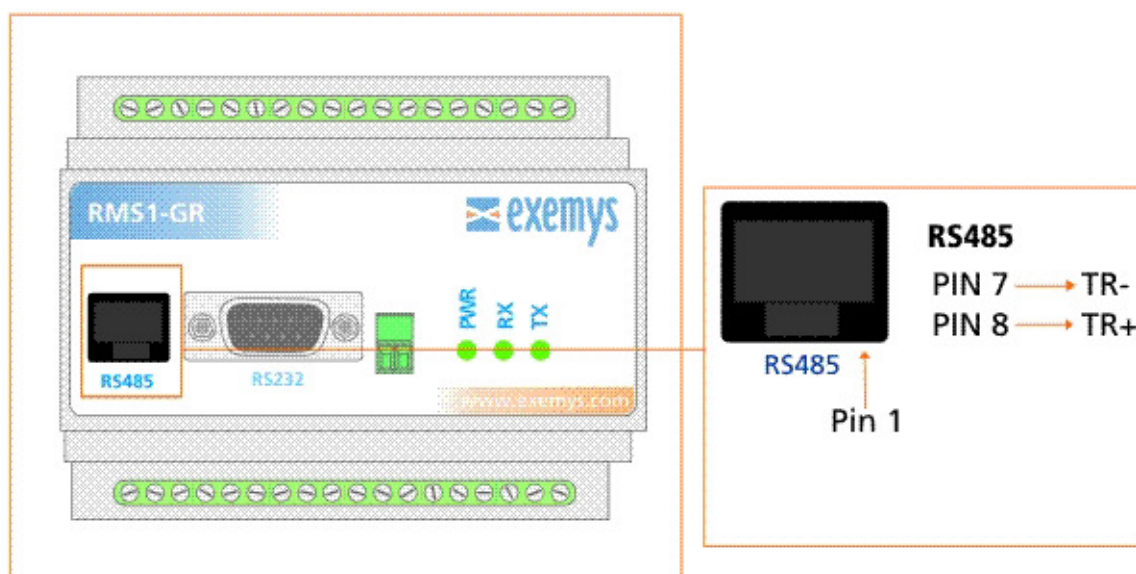

Figure 3 –RS-485 Connection

1.6 LED Indicators

RMS1-GR device has 3 LED Indicators: **Power**, **Rx** and **Tx**.

Power LED

This LED indicates different device statuses.

When energizing the equipment, the **Power** LED flickers rapidly during the first 7 seconds, indicating the time to enter the "CFG" command that gives you access to the configuration of the device. If you have not entered the command within this time, the **Power** LED remains ON during the rest of the operation, indicating that the equipment is energized.

In case the command CFG is entered, the **Power** LED flickers slower while remaining in the configuration mode. When you exit this mode, the LED remains permanently ON.

Tx and Rx LED's

The **Rx** LED flickers when it receives a Modbus packet from the master, even if this packet is not for the slave ID that is receiving it.

The **Tx** LED flickers when a valid Modbus packet is sent to the master. When exceptions are sent it does not flicker.

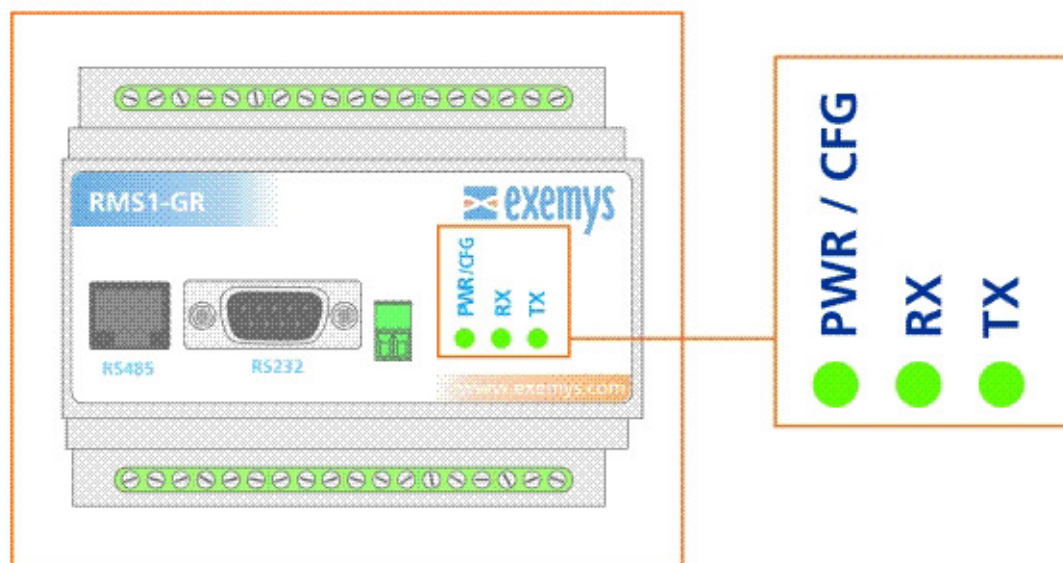

Figure 4 – LED's in the front panel

Power LED	Rx LED	Tx LED	Description
Very fast blink			RMS1-GR is starting. 7 seconds are given to enter the configuration mode through the CFG command via console.
Slow blink			RMS1-GR has entered the configuration mode of the equipment.
	Single blink		RMS1-GR is receiving a Modbus packet from the master.
		Single blink	RMS1-GR is sending a valid Modbus packet to the master.
Steady ON			RMS1-GR is configured and ready to respond to queries from the Modbus Master.

Chapter 2

2 Models

2.1 Models

The RMS1-GR family of products has different types of digital and analog inputs and outputs.

- Up to 16 Digital Inputs, Opto-isolated or transistor
- Up to 16 Digital Outputs, Transistor or with relays
- UP to 6 analog inputs (0-10V)



ORDER CODE

RMS1 - AB - 110 - CD - EF - GR - MB

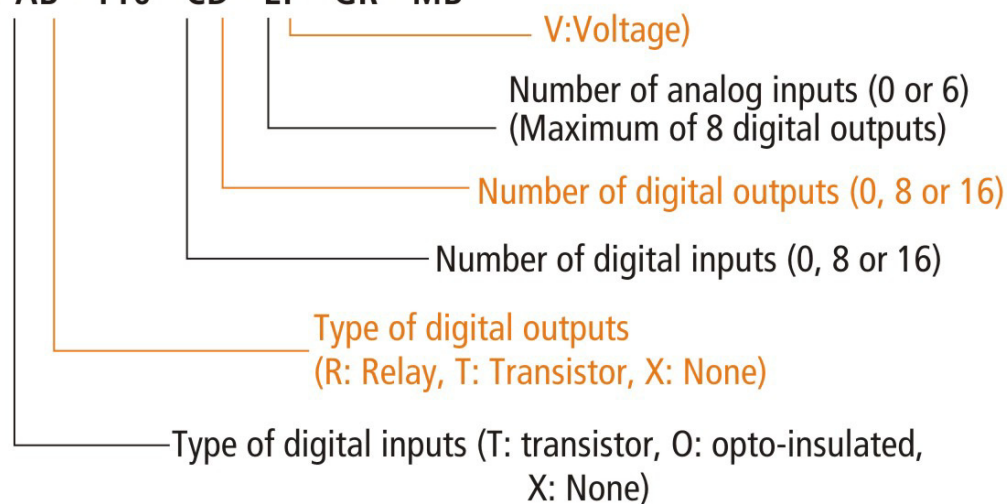

Example: RMS1-OR-110-1616-0X-GR-MB 16 opto-insulated inputs
 16 outputs to relay
 No analog inputs

Chapter 3

3 Serial Configuration

3.1 General Description

The RMS1-GR equipment features a configuration mode through a very intuitive Serial console that allows quick and simple configuration of the equipment.

You gain access to the configuration menu within 7 seconds after powering up the equipment. It starts with a serial port configuration of 9600, 8, N, 1 and you gain access to the menu by entering "CFG" (not case sensitive). The equipment will remain in the configuration menu until a restart or the selection of the exit option in such menu. After this step, the equipment is ready to accept queries from any Modbus master.

The menu has numerical options, that is, the user can only enter numbers to select different configurations. By pressing the ESC key you go backwards in the menu, undoing the previously entered option.

3.2 Screens and Configuration Menus

Soon after CFG is entered you gain access to the main menu:

Main Menu

```
Configuration of RMS1 - XXXX (Firmware V.x.y.z)
-----
```

- 1) Modbus mode
- 2) Serial Port
- 3) ID number
- 4) Exceptions
- 5) Modbus Master
- 6) Show configuration
- 7) Exit

XXXX: is the equipment model.

V.x.y.z: is the Firmware version of the equipment.

Through the numeric keys you can access any of the submenus.

Selecting option (1) in the main menu you can select the Modbus mode to be used, ASCII or RTU.

In the "Modbus" submenu

```
Modbus mode
-----
```

- 1) RTU
 - 2) ASCII
- ESC returns to the previous menu

Selecting option (2) in the main menu you can gain access to the configuration of the serial port parameters, either, Baud Rate, Data Bits or Parity Bits.

In the "Serial Port" submenu

Serial port

1) Baud Rate
2) Data Bits
3) Parity
ESC returns to previous menu

Selecting option (3) of the main menu you can change the ID number of the Modbus Slave.

In the "ID Number" submenu

ID Number

ESC returns to previous menu, ENTER saves the number.

Enter the ID Number (1 - 254) [current = 25]:
Selecting option (4) of the main menu you can activate or deactivate the exceptions as responses of the Modbus Slave.

In the "Exceptions" submenu

Exceptions

1) Activated <-
2) Deactivated
ESC returns to the previous menu.

Selecting option (6) of the main menu you can visualize the current equipment configuration.

In the "Modbus master" submenu

Modbus Master

1) Enabled
2) Disabled <-
3) Timeout
4) Time between queries

ESC returns to previous menu

Selecting option (6) of the main menu you can visualize the current equipment configuration.

In the "Show Configuration" submenu

Current configuration

Modbus: ASCII
Serial: Baud Rate: 9600
 Data Bits: 8 Bits
 Parity: No Parity
Slave: 25
Exceptions: Activated

Selecting option (7) of the main menu you exit saving the last updated configuration.

Chapter 4

4 Modbus Map

4.1 Description of the Modbus Map

The Modbus Map is shown below with the memory zones corresponding to each one of the registers of the Modbus Slave.

Memory Area	Address	Description
INPUT REGISTER	30.001 to 30.006	Analog Inputs
	30.007 to 30.008	Reserved
	30009	Digital Inputs
	30010	Reserved
	30011	Digital Outputs
	30012	Reserved
INPUT STATUS	10001 to 10016	Digital Input 1 to 16
COIL STATUS	00001 to 00016	Digital Output 1 to 16
HOLDING REGISTER	40001 to 40012	Register 1 up 10 and Register 12 are general purpose only. Register 11 is for Digital Output write.

The RMS1-GR has 16 digital inputs, 16 digital outputs and 6 analog inputs.

It should be noted that address 30009 of the INPUT REGISTER, which contains the digital input statuses of the equipment, bit 0 (or the least significant) corresponds to digital input 1, and bit 15 (the most significant) corresponds with digital input 16.

The same thing happens with address 30011 of the INPUT REGISTER, which contains in this case, the status of digital outputs, bit 0 (or the least significant) corresponds to digital output 1, and bit 15 (or most significant) corresponds with digital output 16.

The INPUT STATUS register of address 10001 to 10016 contains in each one of its addresses the individual status of each one of the digital inputs.

The COIL STATUS register 00001 to 00016 contains in each one of its addresses the individual status of each one of the digital inputs.

The HOLDING REGISTER 40001 to 40010 and 40012 are used for general purpose only. This means that you can save data for later use. The register 40011 is used to write all the Digital Outputs at the same time. If you write any Digital Output the register's value will change too.

Ex.

If you write '2' in the 40011 register.

```
40011: <00002> → 00001: <0>
                   00002: <1>
                   00003: <0>
                   00004: <0>
                   00005: <0>
                   00006: <0>
                   00007: <0>
                   00008: <0>
                   00009: <0>
                   00010: <0>
                   00011: <0>
                   00012: <0>
                   00013: <0>
                   00014: <0>
                   00015: <0>
                   00016: <0>
```

Now it will change COIL 00001 register's value, writing to it '1'. The 40011 register's value will change to '0003'.

```
00001: <1> → 40011: <00003>
00002: <1>
00003: <0>
00004: <0>
00005: <0>
00006: <0>
00007: <0>
00008: <0>
00009: <0>
00010: <0>
00011: <0>
00012: <0>
00013: <0>
00014: <0>
00015: <0>
00016: <0>
```

If you write a value bigger than the equipment can handle (if it has 16 Digital Outputs you can write a value less than 65535) it only will write the less significant value.

Ex.

If the equipment has 8 Digital Outputs and you write '65000' the value that will be written is '232' because the last 8 bits of the value count.

Chapter 5

5 Modbus master (I/O Tunnel)

The Modbus master mode allows you to create a digital I/O tunnel using two RMS1-GR devices. Module digital inputs will be replicated on the other's outputs and vice versa.

These are the requisites to make this configuration work.

- 2 RMS1-GR, set up as Master and the other as slave (master disabled)
- Same serial port configuration (baud rate, parity, Modbus type)
- Same Modbus ID

On the master module you can also set the message time out and time between polls. Typically you won't have to modify these values if the modules are connected using a wire (direct RS232 or RS485 connection)

RS232

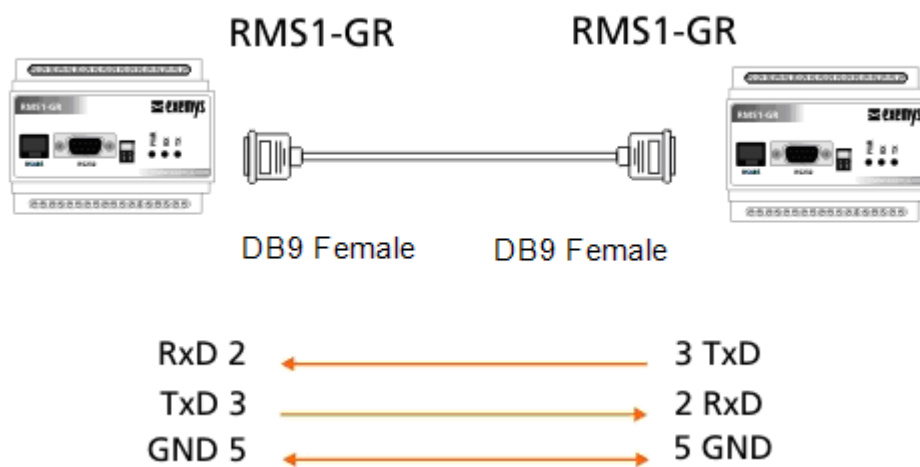

RS485

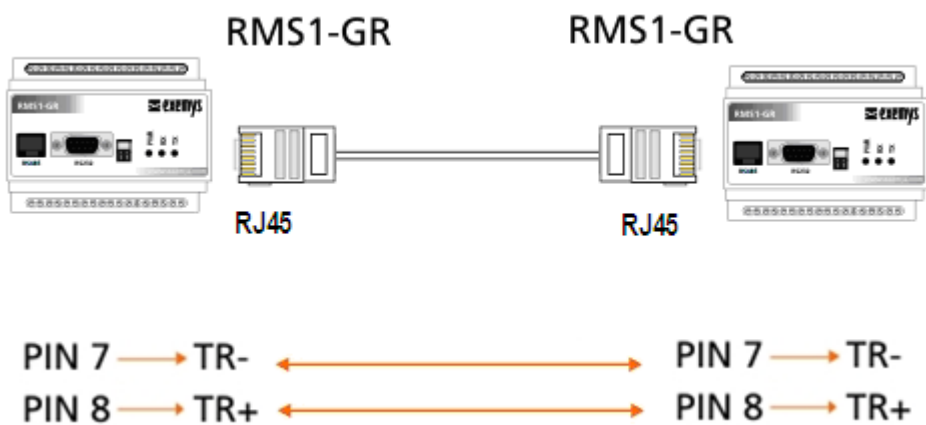

Chapter 6

6 Pin out

6.1 Abbreviations and definitions

Abbreviations	Description
NC	Not connected
ANx	Analog input (0-10V). X: Input number
INx	Digital Input (opto-isolator /Transistor). X: Input number
OUTx	Digital Outputs (Relay/Transistor). X: Output number
GND	Ground
COM	Opto-isolator or relay common terminal

6.2 Inputs/outputs groups

RMS1-GR's input and output terminals are divided into groups depending on IO type.

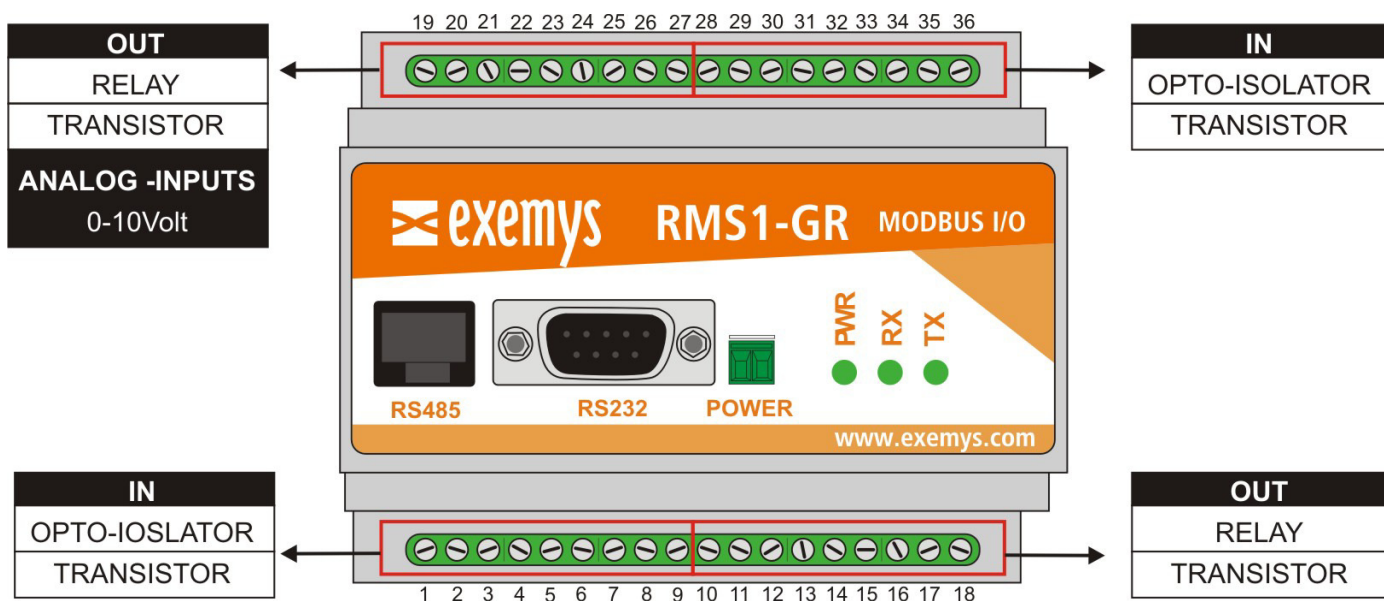

6.3 Pin out of existing models

RMS1-TT-110-1616-0X-GR-MB

RMS1-TT-110-1616-0X-GR-MB													MODBUS REMOTE I/O				
IN1	IN2	IN3	IN4	IN5	IN6	IN7	IN8	GND	OUT1	OUT2	OUT3	OUT4	OUT5	OUT6	OUT7	OUT8	GND
1	2	3	4	5	6	7	8	9	10	11	12	13	14	15	16	17	18

RMS1-TT-110-1616-0X-GR-MB													MODBUS REMOTE I/O				
IN16	IN15	IN14	IN13	IN12	IN11	IN10	IN9	GND	OUT16	OUT15	OUT14	OUT13	OUT12	OUT11	OUT10	OUT9	GND
36	35	34	33	32	31	30	29	28	27	26	25	24	23	22	21	20	19

RMS1-TT-110-168-6V-GR-MB

RMS1-TT-110-168-6V-GR-MB													MODBUS REMOTE I/O				
IN1	IN2	IN3	IN4	IN5	IN6	IN7	IN8	GND	OUT1	OUT2	OUT3	OUT4	OUT5	OUT6	OUT7	OUT8	GND
1	2	3	4	5	6	7	8	9	10	11	12	13	14	15	16	17	18

RMS1-TT-110-168-6V-GR-MB													MODBUS REMOTE I/O				
IN16	IN15	IN14	IN13	IN12	IN11	IN10	IN9	GND	NC	AN6	AN5	NC	AN4	AN3	GND	AN2	AN1
36	35	34	33	32	31	30	29	28	27	26	25	24	23	22	21	20	19

RMS1-OR-110-168-6V-GR-MB

RMS1-OR-110-168-6V-GR-MB																	MODBUS REMOTE I/O
IN1	IN2	IN3	IN4	IN5	IN6	IN7	IN8	COM1	OUT1	OUT2	OUT3	OUT4	OUT5	OUT6	OUT7	OUT8	COM2
1	2	3	4	5	6	7	8	9	10	11	12	13	14	15	16	17	18

RMS1-OR-110-168-6V-GR-MB																	MODBUS REMOTE I/O
IN16	IN15	IN14	IN13	IN12	IN11	IN10	IN9	COM3	NC	AN6	AN5	NC	AN4	AN3	GND	AN2	AN1
36	35	34	33	32	31	30	29	28	27	26	25	24	23	22	21	20	19

RMS1-OR-110-1616-0X-GR-MB

RMS1-OR-110-1616-0X-GR-MB																	MODBUS REMOTE I/O
IN1	IN2	IN3	IN4	IN5	IN6	IN7	IN8	COM1	OUT1	OUT2	OUT3	OUT4	OUT5	OUT6	OUT7	OUT8	COM2
1	2	3	4	5	6	7	8	9	10	11	12	13	14	15	16	17	18

RMS1-OR-110-1616-0X-GR-MB																	MODBUS REMOTE I/O
IN16	IN15	IN14	IN13	IN12	IN11	IN10	IN9	COM3	OUT16	OUT15	OUT14	OUT13	OUT12	OUT11	OUT10	OUT9	COM4
36	35	34	33	32	31	30	29	28	27	26	25	24	23	22	21	20	19

***NOTE:** The terminals that are not showed in the graphics are not used in that particular model.

Appendix A

A Technical Specifications

The minimum and maximum admissible values for inputs, voltage outputs, as well as power consumption of RMS1-GR are detailed below:

1. Power Consumption

RMS1-GR without relays	
Input Voltage	Maximum
12 Vdc	70 mA
24 Vdc	70 mA

RMS1-GR with 8 relays	
Input Voltage	Maximum
12 Vdc	160 mA
24 Vdc	110 mA

RMS1-GR with 16 relays	
Input Voltage	Maximum
12 Vdc	250 mA
24 Vdc	160 mA

2. Digital inputs

In order to activate digital inputs an external continuous voltage must be applied. This power supply has to share the GND terminal with the RMS1-GR power supply. If necessary, the same power supply used to power the RMS1-GR can be used.

The input is of a sinking type, it accepts PNP sourcing type sensors or devices.

Parameter	Minimum	Maximum	Units
Applied voltage	3.5	28	Vdc
Input impedance	2	-	K Ω

Two examples of how to connect directly from the same power source of the RMS1-GR as well as an external power supply where it can be seen that they must share a common terminal are shown.

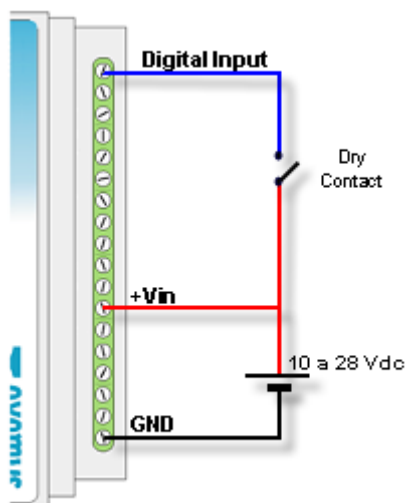

Digital input with single power supply

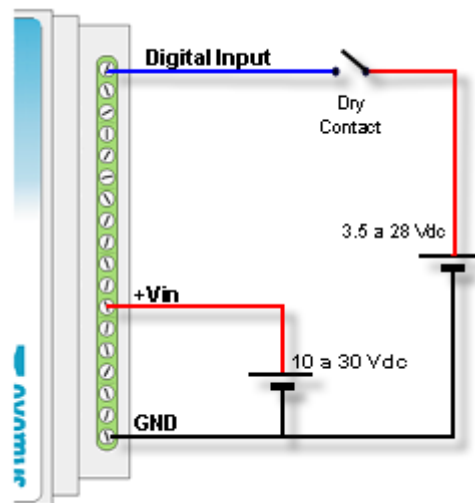

Digital input with double power supply

3. Digital outputs

The digital outputs are of the open collector type. The load to be connected must be supplied with an external power supply and they must share the same GND terminal with the RMS1-GR power supply. If necessary, the same power supply to power the equipment can be used. The output is of the NPM sourcing type.

Parameter	Value
Maximum Voltage	45 Vdc
Maximum Current	50 mA

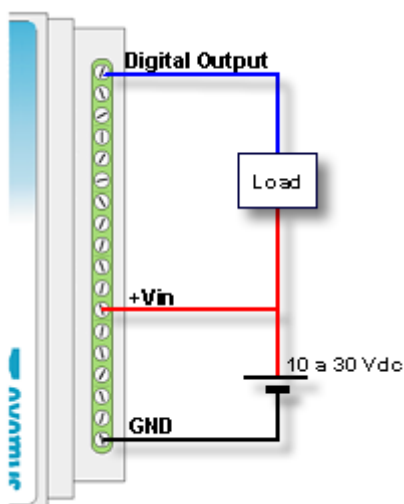

Digital output with single power supply

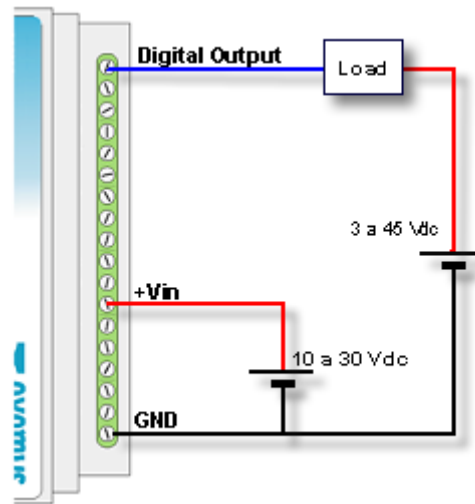

Digital output with double power supply

4. Digital output to drive a relay

When one digital output is used to a relay, it is necessary to add into the connection a protection diode to avoid damage to the equipment. The diode must be connected in reverse (the anode to the output terminal of the equipment and the cathode to the positive terminal that feeds the relay). The relay must be fed using an external power supply, sharing the GND terminal to the power supply of the equipment, or if necessary you can use the same source which feeds the RMS1-GR.

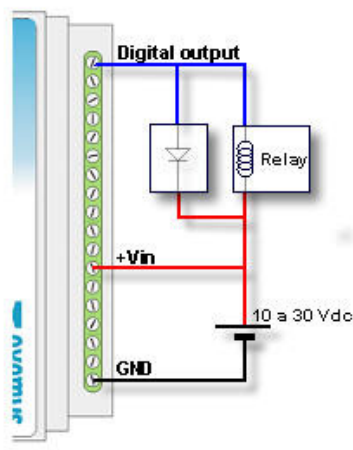

Output with relay (single power supply)

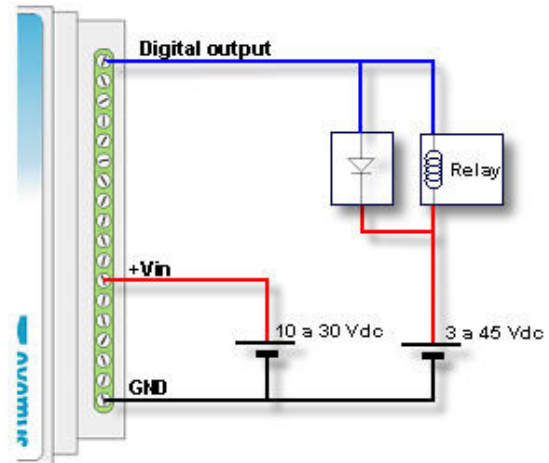

Output with relay (double power supply)

5. The relay outputs

The relay outputs of the RMS1-GR allow us to open or close a circuit using the normal open and common contacts of a relay. The RMS1-GR has the particularity in relay outputs and has a common contact to each group of eight normally open contacts. This common contact can be connected to a positive voltage as GND, taking into account that this common contact is used for the eight terminals normally open.

Parameter	Minimum	Maximum
Max. AC Voltage	125	Vac
Max. DC Voltage	60	Vdc
Max. Current	1	A

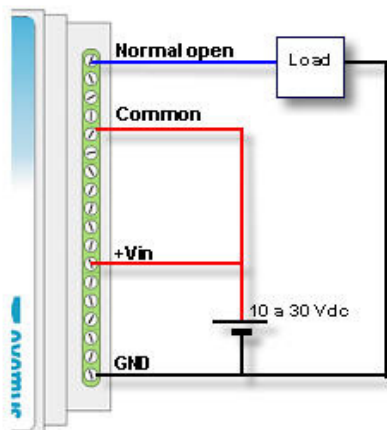

Relay output with single power supply

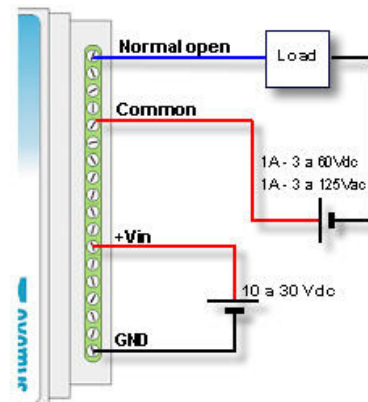

Relay output with double power supply

6. Analog inputs

The analog inputs are referred to the GND terminal of the RMS1-GR, so that the power supply to feed the sensor must share the GND terminal with the RMS1-GR.

6.1 Analog input voltage (0-10V)

Parameter	Value	Units
Full scale	10.00	Vdc
Resolution	0.01	Vdc
Tolerance	±0.2	Full Scale%
Input impedance	13.3	KΩ

Examples of how to connect an analog input of voltage for a single power supply and for independent power supplies are shown below.

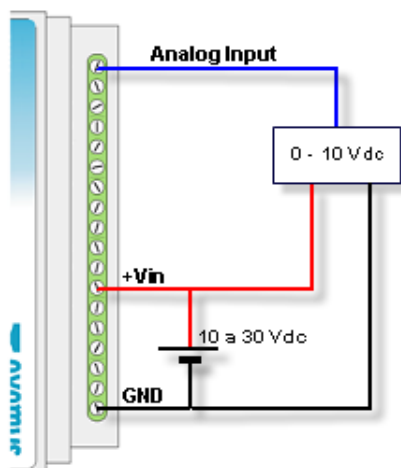

Analog for a single power supply

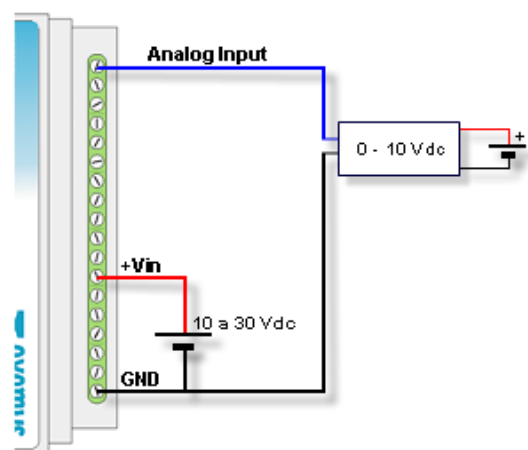

Analog for a double power supply

7. RS485 Port Connection

