

# DABin

User's Manual



**ISO 9001:2000 Certification****Devices Approved By**

LISTED UL60950  
16WU

Exemys Products are in constant evolution to satisfy our customer needs. For that reason, the specifications and capabilities are subject to change without prior notice.

Updated information can be found at [www.exemys.com](http://www.exemys.com)

Copyright © Exemys, 2006. All Rights Reserved.

Rev. 3.1

---

# Table of Contents

---

<b>INTRODUCTION</b>	<b>9</b>
<b>1.1 About this Manual</b>	<b>9</b>
1.1.1 Purpose of the Manual	9
1.1.2 DABin accompanying CD-ROM	9
1.1.3 Information on the Web	10
<b>1.2 DABin General Description</b>	<b>10</b>
1.2.1 Why use DABin?	10
1.2.2 General Description	11
1.2.3 DABin Models	11
<b>INSTALLATION</b>	<b>12</b>
<b>2.1 General Description</b>	<b>12</b>
<b>2.2 Power Connection</b>	<b>13</b>
<b>2.3 Ethernet Connection</b>	<b>13</b>
<b>2.4 Serial Connection</b>	<b>14</b>
2.4.1 RS-232 Serial Connection	14
2.4.2 RS-485 and RS-422 Serial Connection	14
<b>2.5 Inputs and Outputs</b>	<b>15</b>
2.5.1 DABin's Digital Inputs	16
2.5.2 DABin's Digital Outputs	18
<b>2.6 Mounting</b>	<b>19</b>
<b>GENERAL CONFIGURATION</b>	<b>20</b>
<b>3.1 DABin Configuration Manager (DCM)</b>	<b>20</b>
3.1.1 DCM Installation	20
3.1.2 DABin Configuration Manager General Description	21
<b>3.2 Network Configuration Parameters</b>	<b>22</b>
3.2.1 Searching for Exemys Devices in Network	22
3.2.2 DABin Basic Network Parameters	23
3.2.3 Device Locator	25
3.2.4 ARP Table Method for IP Address Configuration	26
<b>3.3 Security in DABin</b>	<b>27</b>
3.3.1 DABin's Security Scheme	27
3.3.2 Changing Standard user Configuration	28
3.3.3 Changing Administrator Password (admin)	29
<b>3.4 Date and Time in DABin</b>	<b>29</b>
3.4.1 How to set up Date and Time in DABin	29

---

---

<b>DABIN MODBUS CONFIGURATION</b>	<b>31</b>
<b>4.1 How DABin Modbus Work</b>	<b>31</b>
<b>4.2 Creating a Modbus Configuration File</b>	<b>34</b>
<b>4.3 Serial Port Configuration</b>	<b>34</b>
<b>4.4 E-Mail Configuration</b>	<b>35</b>
<b>4.5 Tags Configuration</b>	<b>37</b>
4.5.1 Tags Administration	38
4.5.2 Modbus Tags Configuration	38
4.5.3 Digital Inputs and Outputs Tags	40
4.5.4 Internal Tags	41
4.5.5 Value Writing Restrictions	42
4.5.6 Tag Alarm Configuration	42
4.5.7 Tag Value Scaling	43
<b>4.6 Sending and Receiving Configuration</b>	<b>44</b>
4.6.1 Connecting to DABin using DCM	44
4.6.2 Sending and Receiving Configuration	45
<b>DABIN HOSTLINK CONFIGURATION</b>	<b>46</b>
<b>5.1 How DABin Hostlink Work</b>	<b>46</b>
<b>5.2 Creating a Hostlink Configuration File</b>	<b>49</b>
<b>5.3 Serial Port Configuration</b>	<b>49</b>
<b>5.4 E-Mail Configuration</b>	<b>50</b>
<b>5.5 Tags Configuration</b>	<b>52</b>
5.5.1 Tags Administration	53
5.5.2 Hostlink Tags Configuration	53
5.5.3 Digital Inputs and Outputs Tags	54
5.5.4 Internal Tags	55
5.5.5 Value Writing Restrictions	56
5.5.6 Tag Alarm Configuration	57
5.5.7 Tag Value Scaling	57
<b>5.6 Sending and Receiving Configuration</b>	<b>58</b>
5.6.1 Connecting to DABin using DCM	58
5.6.2 Sending and Receiving Configuration	59
<b>DABIN DF1 CONFIGURATION</b>	<b>60</b>
<b>6.1 How DABin DF1 Works</b>	<b>60</b>
<b>6.2 Creating a DF1 Configuration File</b>	<b>63</b>
<b>6.3 Serial Port Configuration</b>	<b>63</b>
<b>6.4 E-Mail Configuration</b>	<b>64</b>

---

---

<b>6.5</b>	<b>Tags Configuration</b>	<b>66</b>
6.5.1	Tags Administration	67
6.5.2	DF1 Tags Configuration	67
6.5.3	Notes on PLC reads and writes for inputs and outputs	69
6.5.4	Digital Inputs and Outputs Tags	69
6.5.5	Internal Tags	70
6.5.6	Value Writing Restrictions	71
6.5.7	Tag Alarm Configuration	72
6.5.8	Tag Value Scaling	73
<b>6.6</b>	<b>Sending and Receiving Configuration</b>	<b>74</b>
6.6.1	Connecting to DABin using DCM	74
6.6.2	Sending and Receiving Configuration	74
<b>WEB SITE DESIGN</b>		<b>76</b>
<b>7.1</b>	<b>Introduction</b>	<b>76</b>
7.1.1	How a Web Site Works in DABin	76
<b>7.2</b>	<b>Applets Web page Design</b>	<b>77</b>
7.2.1	Inserting an Applet in a Web Page	77
7.2.2	The Communication Applet (CApplet)	78
7.2.3	The Data Applets (DApplets)	79
7.2.4	DApplets Parameters	81
<b>7.3</b>	<b>DApplets: The Basic Library</b>	<b>82</b>
7.3.1	The Number Applet: num.class	82
7.3.2	The Bar Applet: bar.class	82
7.3.3	The Image Applet: img.class	82
7.3.4	The Vectorial Applet: vec.class	83
7.3.5	The Text Applet: txt.class	83
<b>7.4</b>	<b>Static Pages (SSI)</b>	<b>84</b>
7.4.1	Inserting a SSI in HTML Code	84
7.4.2	The Tag Value in SSI	84
7.4.3	The Alarm Value in SSI	85
7.4.4	The Text by Value in SSI	85
7.4.5	Execute Links in SSI pages	86
<b>7.5</b>	<b>Creating the Web site file</b>	<b>87</b>
7.5.1	Administration of files in a Web Site Archive	88
7.5.2	Transferring the Web Site	88
7.5.3	Using a Standard FTP Client	89
<b>TOOLS</b>		<b>91</b>
<b>8.1</b>	<b>The DCM Tag Monitor</b>	<b>91</b>
<b>8.2</b>	<b>Serial Commands Console</b>	<b>92</b>
8.2.1	Resetting configuration to factory defaults	93
8.2.2	Changing the Administrator password	93
8.2.3	Seeing the firmware version and ending the commands console	93

---

<b>A. COMMAND SET DOWNWARD COMPATIBILITY IN NEWER ALLEN-BRADLEY PLCS</b>	<b>95</b>
<b>B. DATA LOGGING</b>	<b>96</b>
<b>B.1. Introduction</b>	<b>96</b>
<b>B.2. Configuration</b>	<b>96</b>
<b>B.3. Reading the logged data</b>	<b>98</b>
<b>B.4. SSI with log status</b>	<b>99</b>
<b>B.5. Example</b>	<b>99</b>

## Tables

Table 1 - Chapters of the Manual	9
Table 2 - DABin CD-ROM Contents	10
Table 3 - DABin Models	11
Table 4 - Yellow Indicator Led Status Code	14
Table 5 - Digital Inputs Technical Specifications	17
Table 6 - Digital Outputs Technical Specifications	18
Table 7 - Users and their access to DABin	28
Table 8 - Types of Modbus Tags and its representation	40
Table 9 - Address Ranges in Modbus DABin	40
Table 10 - DABin Internal Tags	41
Table 11 - Types of Hostlink Tags and its representation	54
Table 12 - DABin Internal Tags	55
Table 13 - Types of DF1 Tags and its representation	69
Table 14 - File Types of DF1 Tags	69
Table 15 - DABin Internal Tags	70
Table 16 - DABin's Web Site characteristics	77
Table 17 - Communication Applet Parameters	78
Table 18 - State Messages in the Information Dialog box	80
Table 19 - Error Messages in Information Dialog box	80
Table 20 - Alarm Messages in the Information Dialog box	80
Table 21 - DApplets Common Parameters	81
Table 22 - Color Values	81
Table 23 - Number Applet Parameters	82
Table 24 - Bar Applet Parameters	82
Table 25 - Image Applet Parameters	83
Table 26 - Vectorial Applet Parameters	83
Table 27 - Text Applet Parameters	83
Table 28 - Format specifiers for VALUE SSI Command	85

## Figures

Figure 1 - DABin functional diagram	11
Figure 2 - Front and Rear View of DABin	12
Figure 3 - Power connection detail	13
Figure 4 - Connecting DABin to an Ethernet Network	13
Figure 5 - Connection of DABin (DTE) to a PC (DTE) using RS-232 Serial Port	14

Figure 6 - Connector Detail for RS-485 or RS-422 network connection	15
Figure 7 - DABin Connected to RS-485 and RS-422 networks	15
Figure 8 - Inputs and Outputs connectors in different DABin models	16
Figure 9 - Digital Input connected to an external Device with independent power supply	17
Figure 10 - Different ways to connect a Digital Input	17
Figure 11 - Connection of Digital Outputs	18
Figure 12- Wall-mounting adapter	19
Figure 13 – Wall mounting	19
Figure 14 - DCM Main window and its elements	21
Figure 15 - Searching Devices Locally	22
Figure 16 - Remote DABin Search	23
Figure 17 - DABin Network Properties Dialog box	23
Figure 18 - Administrator Password Dialog Box	24
Figure 19 - Device Locator Main window	25
Figure 20 - Device Locator Properties Dialog box	26
Figure 21 - Users & Passwords in the Properties dialog box	28
Figure 22 - Date and Time in the Properties dialog box	30
Figure 23 - Scan Cycle of DABin Modbus	31
Figure 24 - Write Cycle in DABin Modbus	31
Figure 25 - Read Cycle in DABin Modbus	32
Figure 26 - Alarm Control Cycle in DABin Modbus	33
Figure 27 - New File dialog box	34
Figure 28 - Serial Port Configuration Page of DABin Modbus	35
Figure 29 - E-Mail configuration page of DABin Modbus	36
Figure 30 - E-Mail Address Edit Dialog box	37
Figure 31 - Tags Page configuration for DABin Modbus	38
Figure 32 - Modbus Tag Configuration	39
Figure 33 - Digital Inputs / Output Tag Configuration	40
Figure 34 - Internal Tag List	41
Figure 35 - Value Configuration Page	42
Figure 36 - Alarm Configuration Page	43
Figure 37 - Scale configuration page	44
Figure 38 - Receiving Configuration from DABin	45
Figure 39 - Sending Configuration to Connected DABin	45
Figure 40 - Scan Cycle of DABin Hostlink	46
Figure 41 - Write Cycle of DABin Hostlink	46
Figure 42 - Read Cycle of DABin Hostlink	47
Figure 43 - Alarm Control Cycle of DABin Hostlink	48
Figure 44 - New File dialog box	49
Figure 45 - Serial Port Configuration Page for DABin Hostlink	50
Figure 46 - E-Mail configuration page of DABin Hostlink	51
Figure 47 - E-Mail Address Edit Dialog box	52
Figure 48 - Tags Page configuration for DABin Hostlink	52
Figure 49 - Hostlink Tag Configuration	53
Figure 50 - Digital Inputs / Output Tag Configuration	55
Figure 51 - Internal Tag List	56
Figure 52 - Value Configuration Page	56
Figure 53 - Alarm Configuration Page	57
Figure 54 - Scale configuration page	58
Figure 55 - Receiving Configuration from DABin Hostlink	59
Figure 56 - Sending Configuration to Connected Hostlink DABin	59
Figure 57 - Scan Cycle of DABin DF1	60
Figure 58 - Write Cycle of DABin DF1	60
Figure 59 - Read Cycle of DABin DF1	61
Figure 60 - Alarm Control Cycle of DABin DF1	62

---

Figure 61 - New File dialog box	63
Figure 62 - Serial Port Configuration Page for DABin DF1	64
Figure 63 - E-Mail configuration page of DABin DF1	65
Figure 64 - E-Mail Address Edit Dialog box	66
Figure 65 - Tags Page configuration for DABin DF1	67
Figure 66 - DF1 Tag Configuration	68
Figure 67 - Digital Inputs / Output Tag Configuration	70
Figure 68 - Internal Tag List	71
Figure 69 - Value Configuration Page	72
Figure 70 - Alarm Configuration Page	72
Figure 71 - Scale configuration page	73
Figure 72 - Receiving Configuration from DABin DF1	74
Figure 73 - Sending Configuration to Connected DF1 DABin	75
Figure 74 - DABin Web Page with Applets	76
Figure 75 - The CApplet in a Web Browser	78
Figure 76 - The Number Applet	79
Figure 77 - Contextual Menu of DApplets	79
Figure 78 - Change Value dialog box	79
Figure 79 - Change value for Digital Tags	79
Figure 80 - Information Dialog box for a Dapplet	80
Figure 81 - The Number Applet	82
Figure 82 - The Bar Applet	82
Figure 83 - The Image Applet	82
Figure 84 - The Vectorial Applet	83
Figure 85 - The Text Applet	83
Figure 86 - New File dialog box	87
Figure 87 - Web Site Window in DCM	88
Figure 88 - FTP Transfer in DCM	89
Figure 89 - DCM Tag Monitor	91
Figure 90 - Tag Write dialog box for Tag Monitor	92

## Listings

---

Listing 1 - A Simple page with a CApplet inserted	78
Listing 2 - The Bar Applet with some Parameters	81
Listing 3 - An SSI command	84
Listing 4 - Standard Link Example	86
Listing 5 - CGI call using the HTTP GET Method	86
Listing 6 - Getting the Web Site file using the FTP.EXE	89
Listing 7 - Sending a Web Site file to DABin's FTP Server usign FTP.EXE	90
Listing 8 - Welcome message to the DABin Serial Commands Console	93
Listing 9 - Using the factreset command to reset configuration to Factory deafults	93
Listing 10 - Usign the password command	93
Listing 11 - Using the ver command to see the current firmware version	93
Listing 12 - Using the end command to finish the Commands Console	94

---

# Chapter 1

## Introduction

In this chapter you will be introduced to the general aspects about this manual and DABin. Use this chapter as a guide for the reading of this manual.

If you are a new User of DABin we recommend you to read the General Description of DABin to have an accurate vision about functions and general characteristics of DABin.

### 1.1 About this Manual

#### 1.1.1 Purpose of the Manual

The purpose of this manual is to provide the correct instructions of Installation, configuration and operation of DABin.

In General, DABin has been developed with easy-of-use philosophy in mind. For this reason, any person with basic knowledge in any of these areas can configure and operate DABin successfully:

TCP/IP Communication

Simple Web Page design

Some experience in Industrial Protocols such as Modbus or Hostlink.

In the chapters specifically written for any of the above areas, the standard user will count with the help of Notes, Warnings and Links of interest on the World Wide Web.

In Table 1 you can see a detailed description of the chapters included in this manual and who may be oriented to in each case.

**Table 1 - Chapters of the Manual**

Chapter	Oriented to
1 - Introduction	All
2 - Installation	Installers and Maintenance
3 - General Configuration	Network Administrators and System Administrators
4 - DABin Modbus Configuration	SCADA Operators or the like (Modbus only Model)
5 - DABin Hostlink Configuration	SCADA Operators or the like (Hostlink only Model)
6 - DABin DF1 Configuration	SCADA Operators or the like (DF1 only Model)
7 - Web Site Design	Programmers and Web Page Designers SCADA Operators or the like
8 - Tools	Programmers and Web Page Designers SCADA Operators or the like

#### 1.1.2 DABin accompanying CD-ROM

DABin accompanying CD-ROM contains the Software needed for proper configuration, samples and the complete documentation of the product.

In Table 2 is shown a detail of the contents of this CD-ROM.

**Table 2 - DABin CD-ROM Contents**

Contents	Description
dcmsetup.exe	Program Application for DABin Configuration (DCM ) Web Page Samples for DABin Configuration Samples for DABin Applets to use in DABin Web Pages
Sun Java Runtime	Java Runtime Environment 2 to make Applets run in your Web Browser
DABin_UM_E.pdf	Manual of DABin
DABIN_DS_E.pdf	DABin Datasheet

### 1.1.3 Information on the Web

To get information about the last changes, firmware and software upgrades, and to keep documentation up to date, enter our Web Site:



ON THE WEB

[www.exemys.com](http://www.exemys.com)

You will also find information about new Exemys products, press releases, accessories and new development tools.

There are published Application Notes and Technical Notes about DABin and other Exemys products.

## 1.2 DABin General Description

### 1.2.1 Why use DABin?

The fast growth up of TCP/IP networks in industry areas facilitated the remote monitoring and supervision, reducing costs and increasing productivity and efficiency.

DABin achieves this in an economic manner, with easy development, almost without maintenance, flexibly and security, using the software tools you already know: a standard Web Browser, a standard E-Mail client, an FTP client, etc.

**Economic:** The enormous infrastructure of a SCADA system is not needed with DABin, reducing development costs, maintenance and support.

**Rapid Deployment:** DABin may be configured and working in just hours, not months or even years as most SCADA applications.

**Universal Access:** All DABin functionality (including DABin configuration) is available to an authorized user with an Internet connection in any place of the World.

**Flexibility:** The innumerable ways to configure DABin makes it easy-to-adapt to any application. DABin Digital inputs and outputs, makes possible to connect DABin to non-industrial protocol-enabled devices.

**No Risk:** Like any SCADA system DABin provides all monitoring and supervision functionality remotely, without the risk of personnel or equipment.

### 1.2.2 General Description

To achieve all these goals, DABin incorporates a complete and efficient functionality: Acquires data from an embedded Serial Port, using an industrial protocol like Modbus or Hostlink, and from its digital inputs.

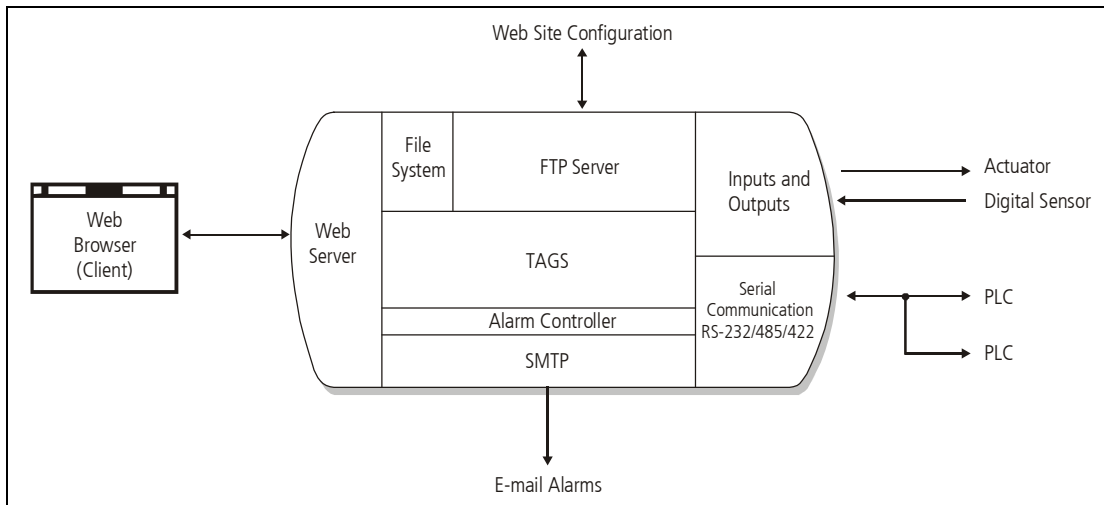

Figure 1 - DABin functional diagram

An Embedded Web Server lets the operator see DABin’s internal Web Site to visualize the acquired values and change them, from any standard Web Browser. DABin can send one or more e-mails notifying the Alarm State of any of the acquired values. The operator can actuate on DABin’s outputs remotely from the Web. The embedded Web Site can be changed easily using a standard FTP client or the application software distributed with DABin.

### 1.2.3 DABin Models

Exemys launched to market different DABin Models. Depending the needs, a different model with more or less Digital Inputs and Outputs can be chosen, or with configurable RS-232/485/422 Serial Port.

Table 3 - DABin Models

Model	Serial Protocol	Inputs	Outputs	Serial Ports
DABin - 1083 - ST - MB	Modbus ASCII / RTU	8	3	1 RS-232 Serial Port
DABin - 1C43 - ST - MB	Modbus ASCII / RTU	4	3	1 Configurable RS-232/485/422 Serial Port
DABin - 1083 - ST - HL	Hostlink	8	3	1 RS-232 Serial Port
DABin - 1C43 - ST - HL	Hostlink	4	3	1 Configurable RS-232/485/422 Serial Port
DABin - 1083 - ST - DF1	DF1	8	3	1 RS-232 Serial Port
DABin - 1C43 - ST - DF1	DF1	4	3	1 Configurable RS-232/485/422 Serial Port

# Chapter 2

## Installation

DABin can be easily installed following the instructions in this Chapter. Connection to Power, Ethernet, Serial Ports and Digital Inputs and Outputs are described in detail.

### 2.1 General Description

DABin's case has the following elements:

1. Ethernet 10BaseT RJ-45 Connector with indicator Leds.
2. Serial Port RS-232 DTE DB9-Male Connector.
3. Terminal Block including:
  - Power (VIN).
  - Connection for Common reference for Digital Inputs-Outputs (GND).
  - Voltage Output for connection of dry contacts to Digital Inputs (V+).
  - Digital Inputs.
  - Digital Outputs.
  - Serial Port in mode RS-485 (available in some models)
  - Serial Port in mode RS-422 (available in some models)
4. Wall mounting accessory.
5. DIN Rail Mounting accessory (optional).

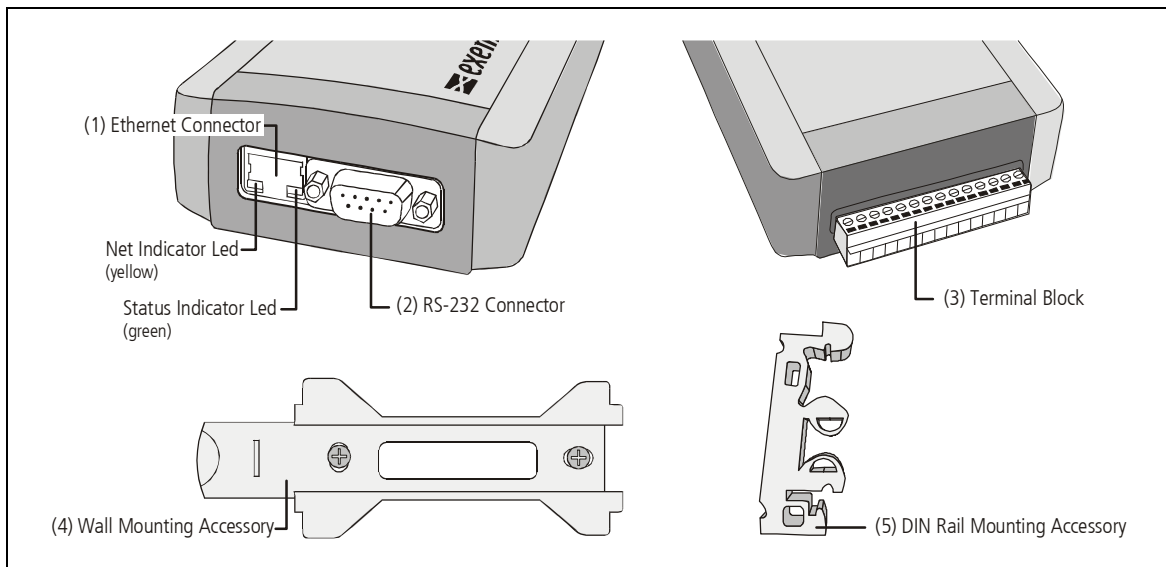

Figure 2 - Front and Rear View of DABin



NOTE

For optional accessories for installation ask our sales team.

## 2.2 Power Connection

This product must be installed and powered according to its ratings and installation instructions. The unit shall be powered from a NEC class 2 source of supply or a LPS source, having an output rated 9-26 Volts AC, 9-30 Volts DC, 200 mA min.

The installation of this product inside shall be in accordance with the NEC, specifically Article 725-54. Wiring from/to this unit is to be Class 2 wiring and shall be segregated from other wiring in the equipment as noted in the NEC.

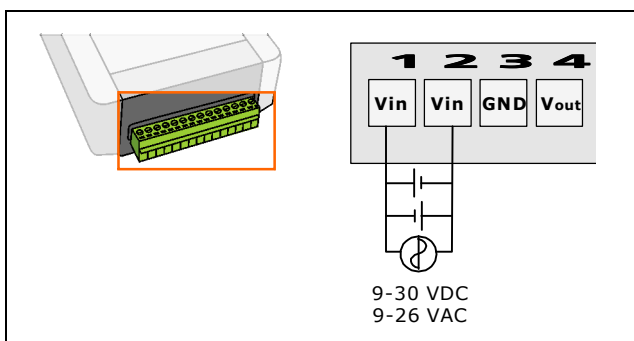

Figure 3 - Power connection detail

The Vout voltage output is provided in order to connect dry contacts to DABin's Digital Inputs. It can drive up to **60mA** and it is fuse protected.

## 2.3 Ethernet Connection

Figure 4 shows the connector RJ-45 Ethernet 10BaseT (1) for Ethernet network connection. It can be connected to a LAN through a Hub or Switch, or to a PC directly using a crossover cable.

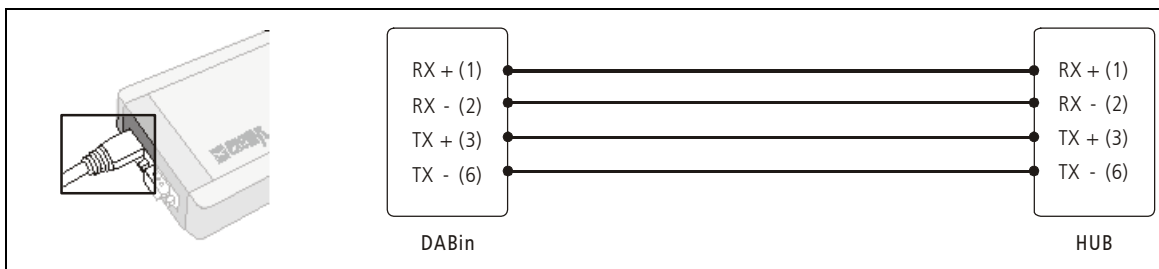

Figure 4 - Connecting DABin to an Ethernet Network

The yellow indicator led, included in the Ethernet connector, shows the network connection status and if DABin's network parameters are properly configured.



TIP

Although DABin has no assigned IP Address, the Device Locator application software can be used in a PC in the same Network in order to test that Ethernet connection has been properly set up.

▶ See also: "Device Locator" on page 25

**Table 4 - Yellow Indicator Led Status Code**

Yellow Led Code	Description
It is 1/2 second on and 1/2 off	Has been turned on and it is initializing.
Turned on constantly	Is searching for a DHCP Server
It blinks very fast	There is no carrier in the Ethernet connection
It is turned off during almost a second and it turns on for short periods of time (like a beacon)	It has an IP Address and it is working properly
It is turned on during almost a second and it turns off for short periods of time	DABin detects carrier in Ethernet connection but has no assigned IP Address.

## 2.4 Serial Connection

DABin provides an RS-232 Serial Port in all models. In some models, the Serial Port can be configured as either RS-485 or RS-422.

The RS-232 DTE DB9-Male connector (2) can be used to connect any device using the same DABin's Protocol (Modbus), or also to enter the Serial Commands Console.



**In models where DABin's Serial Port can be configured as RS-485/422, it is no necessary to configure the Serial Port as RS-232 before entering the Serial Commands Console. You can enter the Serial Command Console connecting the Serial Port RS-232 to any PC RS-232 Serial Port although DABin's Serial Port is in other mode.**

### 2.4.1 RS-232 Serial Connection

The RS-232 Serial Connection, included in all DABin models, is found in connector DB9-Male (2). To connect another DTE to DABin's RS-232 Serial Port, use a crossover cable, as shows figure 5.

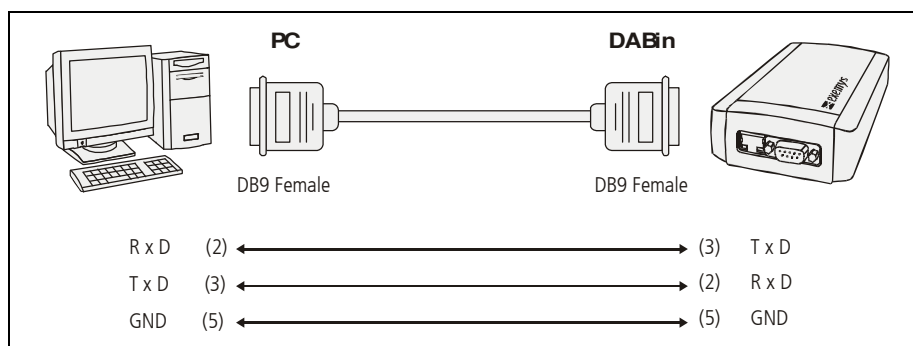

**Figure 5 - Connection of DABin (DTE) to a PC (DTE) using RS-232 Serial Port**

### 2.4.2 RS-485 and RS-422 Serial Connection

In models where the Serial Port can be configured as RS-485 or RS-422, DABin can be connected to RS-485 or RS-422 network for proper data acquisition.

When the Serial Port is configured as either RS-485 or RS-422, a connection must be done through Terminal Block (3). RS-485 network connection uses the last 2 connectors and RS-422 network connection uses the last 4 connectors.

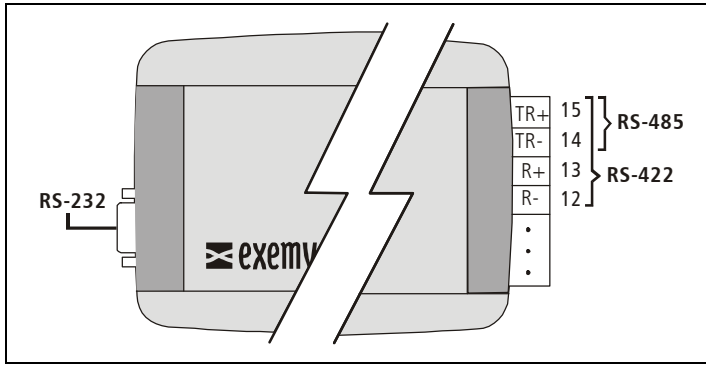

Figure 6 - Connector Detail for RS-485 or RS-422 network connection

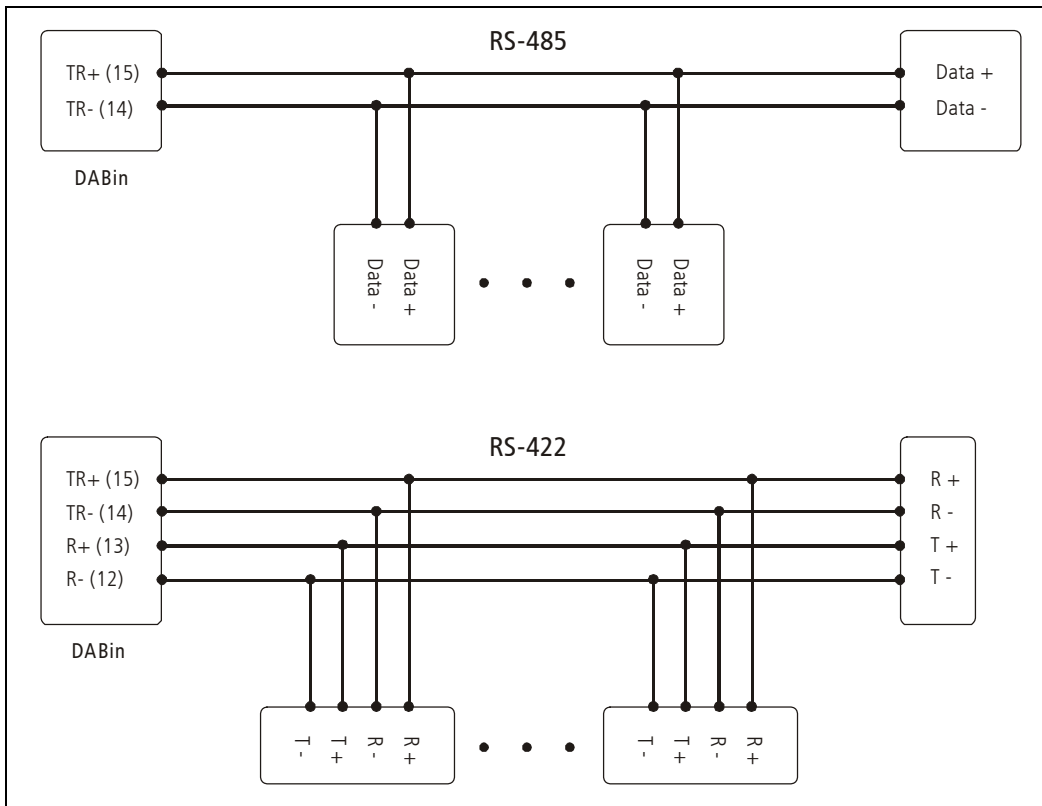

Figure 7 - DABin Connected to RS-485 and RS-422 networks

## 2.5 Inputs and Outputs

The number of Digital Inputs and Outputs provided with DABin depend on models. All Inputs and Outputs can be found at the Terminal Block (3), starting at connector number 5. DABin also provides the special connectors  $V_{out}$  and GND: Voltage output for dry contact connection and reference or common for external Field Devices connection respectively.

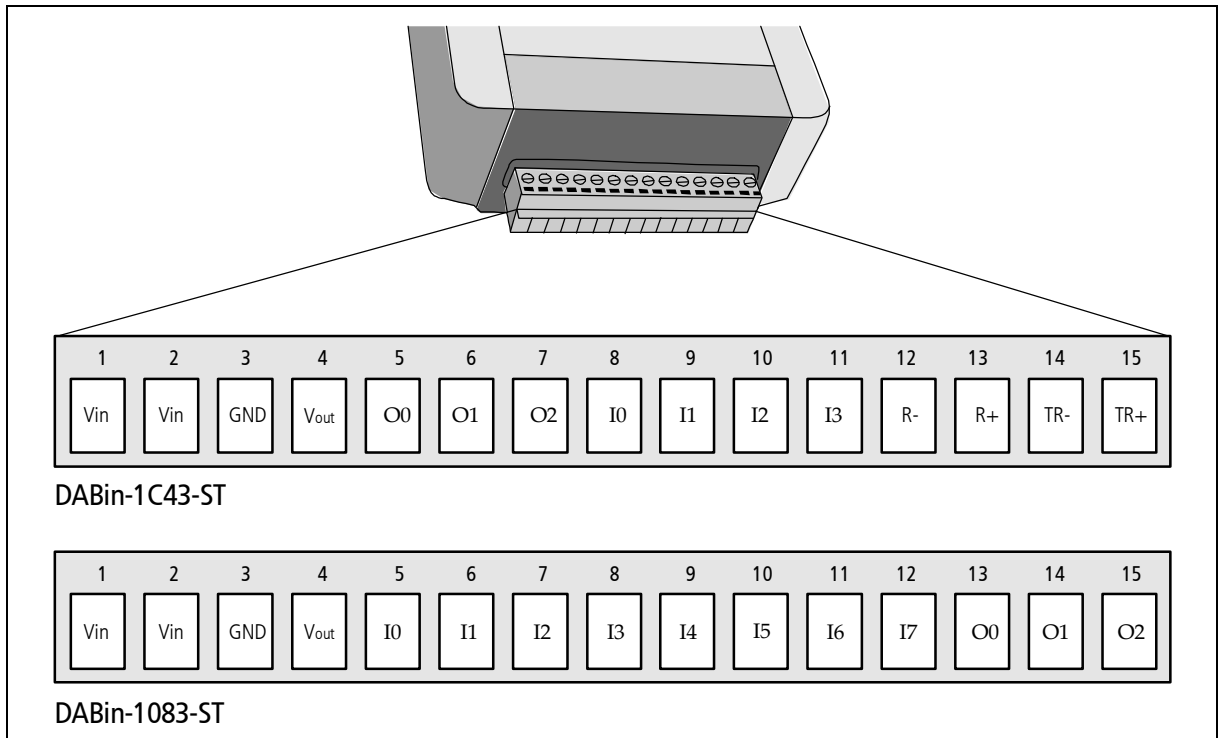

Figure 8 - Inputs and Outputs connectors in different DABin models



For more information about Digital Inputs and Digital Outputs in all Exemys Products, including DABin, refer to Technical Note TN-11 "Inputs and Outputs".

<http://www.exemys.com>

### 2.5.1 DABin's Digital Inputs

DABin's Digital Inputs are based on transistors in Current Sinking Mode, activated when a voltage in the range 3.5 to 28VDC referenced to GND is applied.

This voltage may be provided from either, an external field device working in Current Sourcing Mode or with dry contacts.

To activate Digital Inputs from an external field Device with independent power supply: connect reference GND to Common of that Device, as seen on figure 9.

To activate Digital Inputs with a dry contact with an independent power supply, connect as shown in figure 10A.

To activate Digital Inputs with a dry contact with the same power supply, proceed as shown in figure 10B.

To activate Digital Inputs with a dry contact without any additional power supply, use connector Vout as shown in figure 10C.

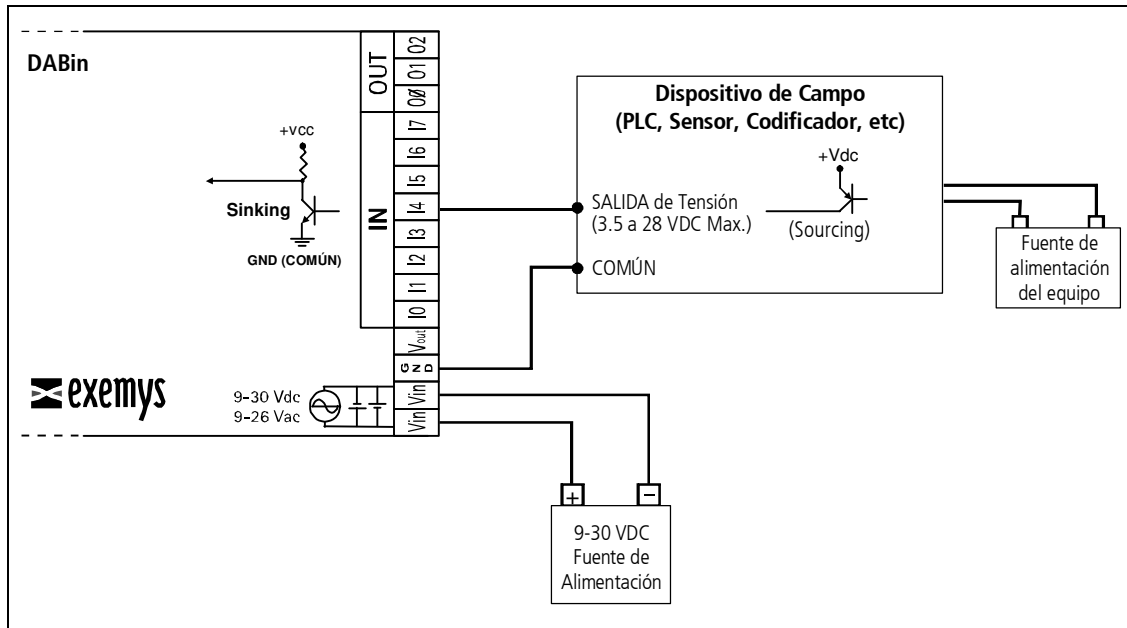

Figure 9 - Digital Input connected to an external Device with independent power supply

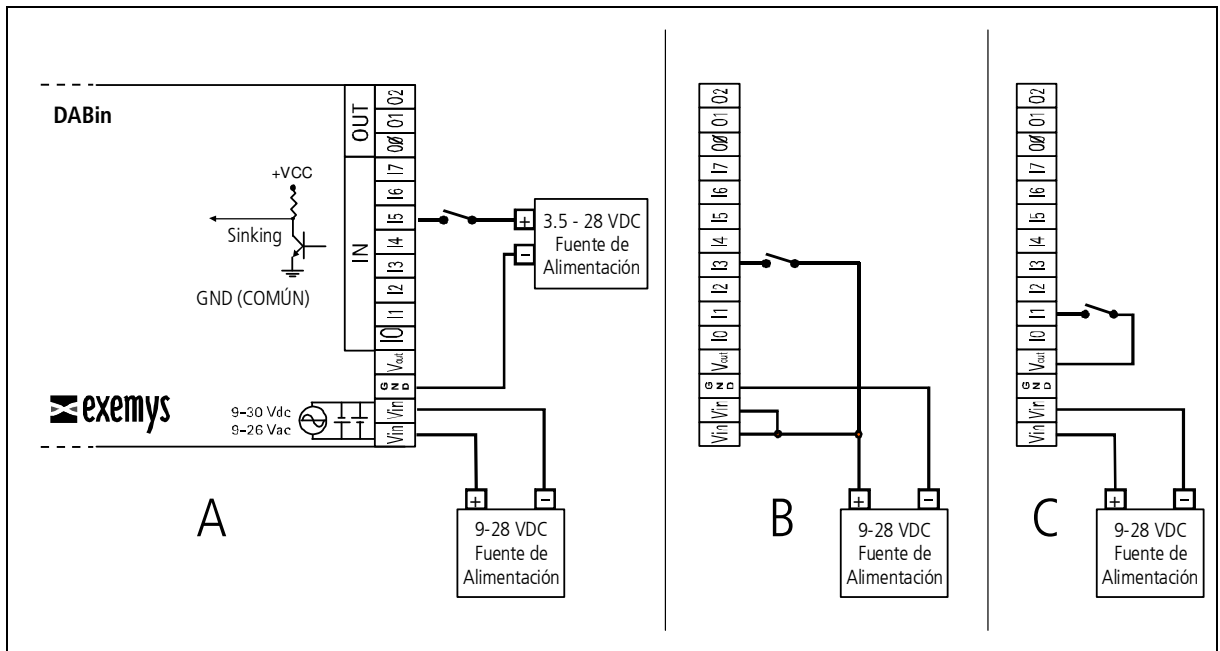

Figure 10 - Different ways to connect a Digital Input

Table 5 - Digital Inputs Technical Specifications

Digital Inputs	
Inputs Type	<i>Sinking.</i> Allows sensors and Current Sourcing Devices
Operating Voltage Range	3.5 to 28 VDC
Input Current	1 to 11 mA

### 2.5.2 DABin's Digital Outputs

DABin's Digital Outputs are Open Collector. Thus when active, they are electrically tied to GND. Any load connected to an output should be powered in the range 3 to 45 VDC.

To connect an Output to a load whose power supply is different to that used to power DABin: Connect the reference GND to the independent power supply reference as shows figure 11A. To connect an Output to a load with the same power supply that power DABin: Connect the reference GND to the power supply reference as shown in figure 11B.

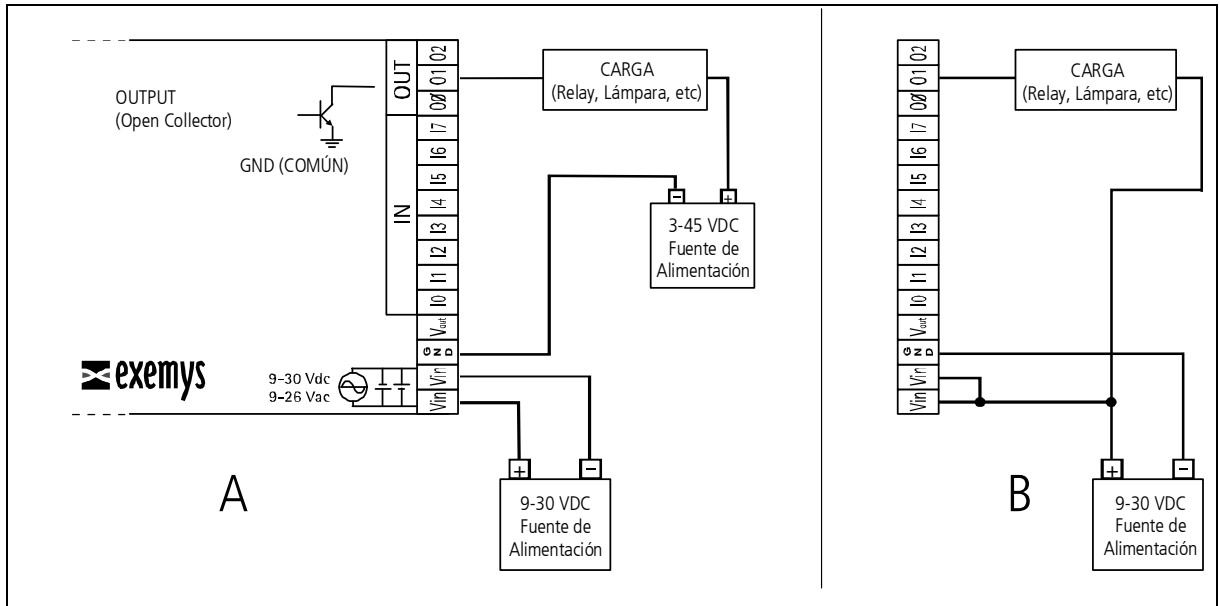

Figure 11 - Connection of Digital Outputs

Table 6 - Digital Outputs Technical Specifications

Digital Outputs	
Output Type	Open Collector. Current Sinking
Maximum Load Voltage	3 to 45 VDC Max.
Current	130mA Max. Per Output

## 2.6 Mounting

Remove the wall-mounting adapter (included) from the device.  
Then mount the adapter to the wall using two screws, as shown in figure 12.

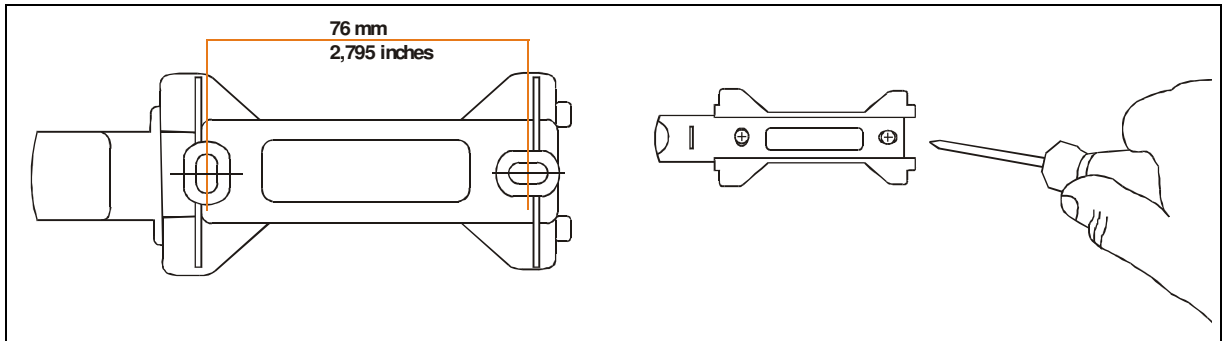

Figure 12- Wall-mounting adapter

Last, attach the device to the fixed adapter, as shown in Figure 13.

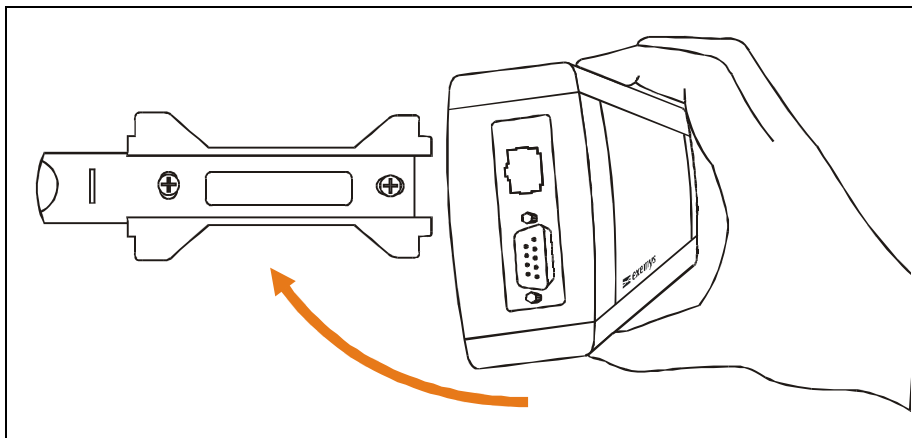

Figure 13 – Wall mounting

# Chapter 3

## General Configuration

Once installed, DABin must receive the general configuration parameters that make it work in your Ethernet Network. This chapter gives detailed instructions of the most fundamental configuration parameters for DABin. These fundamental parameters are network configuration parameters, DABin authorized users and Date and Time.

### 3.1 DABin Configuration Manager (DCM)

DABin Configuration Manager (DCM) is the application program that comes with the product and is used to configure DABin, locally or remotely, through a TCP/IP network.

It has been developed with easy-to-use philosophy allowing configuring either, basic or advanced functions of DABin.

DCM can be installed on Windows 98/Me, Windows 2000/NT4 and Windows XP.



Enter frequently to [www.exemys.com](http://www.exemys.com) to download the latest version of DCM and keep documentation up to date.

DCM doesn't have to be installed in a PC within the same LAN DABin is, but be sure that the application program will have access to DABin, locally or remotely through the TCP/IP network. DCM uses HTTP Protocol to configure DABin once it has a valid IP Address assigned, transparently.

If DABin has never been configured, it will look for a DHCP Server in order to obtain an IP Address at startup. If the network where DABin is installed doesn't have a DHCP Server, use any of the following methods to start configuring DABin for the first time:

Install DCM in a PC within the same LAN DABin is connected to, and use DCM or Device Locator to assign DABin an IP Address.

If no PC in the same LAN DABin is connected to have any of the operating systems supported by DCM or Device Locator, follow the steps of the ARP Table Method to assign DABin an IP Address.

- ▶ See also: "Device Locator" on page 25 and "ARP Table Method for IP Address Configuration" on page 26

#### 3.1.1 DCM Installation

To install DCM follow these steps:

Insert the DABin accompanying CD and execute setup.exe to begin the installation program.

The Welcome screen will appear, follow the instructions of the Installation Wizard that will prompt for the necessary information to complete installation. Click "Next" to continue.

User information: Enter a user name and the name of the company and click "Next" to continue.

**Destination Folder:** Select the destination folder where the application program will be installed.

**Installation Type:** You can choose any of the following installation types: Typical, Minimum or Custom.

**Program Folder:** Enter the name of the Program Folder that will contain all executable elements in your Programs Menu.

Wait for the Installation Wizard to complete copying all the necessary files to your hard disk, and press "Finish" to end installation process.

Once installed you will see a folder in your Programs Menu containing all links to Exemys Application programs installed, DABin Configuration Manager (DCM) and Device Locator.

### 3.1.2 DABin Configuration Manager General Description

Figure 14 shows the main DCM window. The DCM window elements allow easy navigation and configuration of all DABin available simultaneously, and also allows configuration of any Exemys Product network parameters.

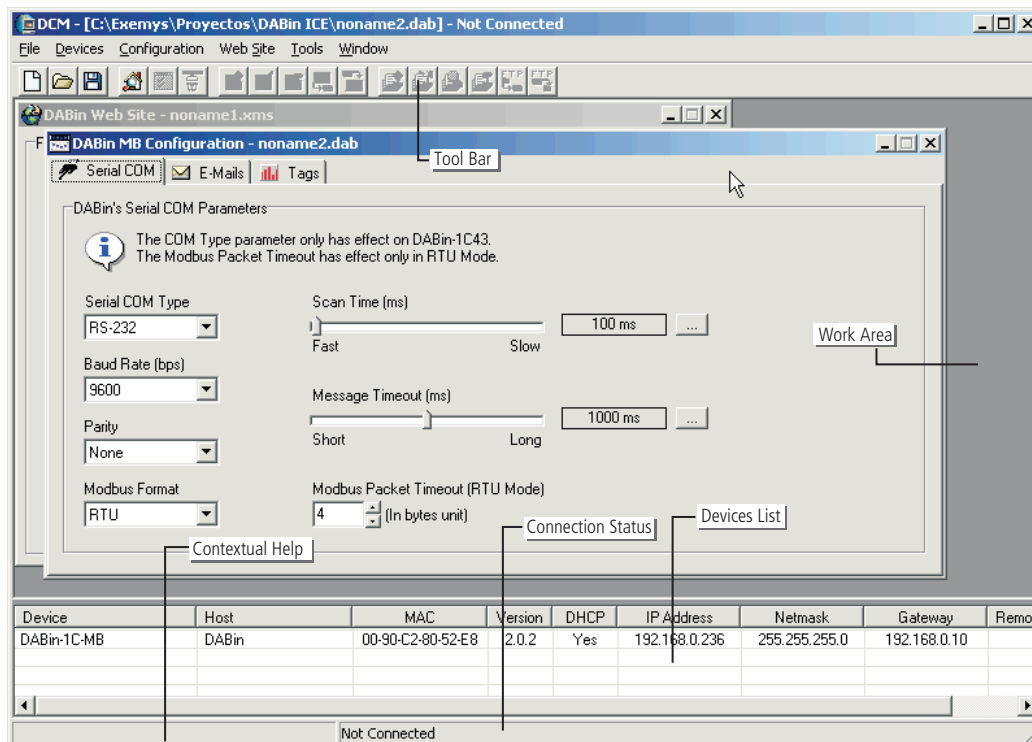

**Figure 14 - DCM Main window and its elements**

These are the elements composing the DCM main window:

**Tool Bar:** At the top is the tool bar. You will find commands also available in the application menus.

**Work area:** In the middle there is the Work area, where all configuration windows will appear.

**Devices List:** Below the work area is the Devices List. It contains all Exemys devices found by DCM (locally or remotely)

**Connection Status:** At the status bar is the text indicating if DCM is connected to a DABin or not.

**Contextual Help:** At the left in the status bar, a panel shows contextual help about the menu and tool bar commands.



The size of the Devices List can be changed, reducing or increasing the Work area. To change its size, move the mouse cursor over the superior division line of the List and drag to the desired size.

## 3.2 Network Configuration Parameters

DABin network parameters must be configured in first. DCM, Device Locator or the ARP Table method described later in this chapter can be used to configure these parameters.

### 3.2.1 Searching for Exemys Devices in Network

The search of all available DABin connected to the network can be achieved locally or remotely. The devices connected to the same LAN can be searched locally. And the devices connected in other networks can be found using the Search Remote Device command.

You can search and configure any Exemys Product using DCM. Remember that searching a non-DABin device can only be done locally.

**To search for devices in the LAN (any Exemys Product):** Click on the button on the tool bar or select command "Search Local Devices" from "Devices" menu. For a couple of seconds, DCM will search devices in the local network and will show them in the Devices List.

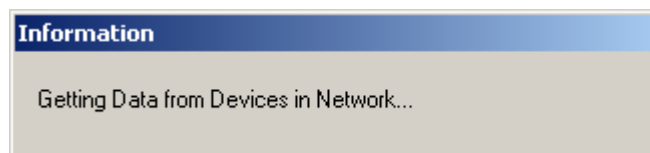

Figure 15 - Searching Devices Locally

**To search for devices remotely beyond the LAN (only DABin):** Select command "Search Remote Device" from menu "Devices". Enter IP Address or Remote Host in the dialog box and click "Ok" to start searching. For a couple of seconds, DCM will search that device and it will show it in the Devices List if found.

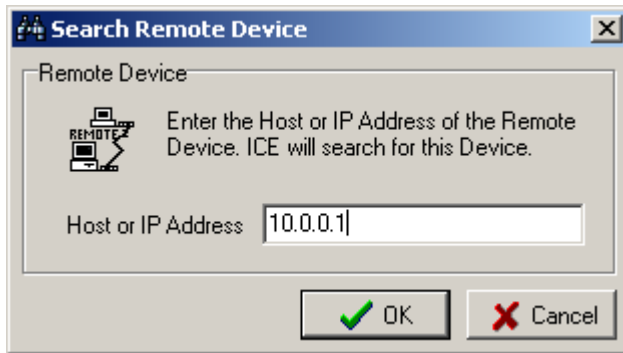

Figure 16 - Remote DABin Search



NOTE

To find a DABin remotely, it must have an assigned IP Address. If you need to find a DABin remotely, and the PC connection to the network needs a HTTP Proxy server, DCM must be configured with the same parameters than your standard Web Browser. Ask your Network administrator for these parameters.

### 3.2.2 DABin Basic Network Parameters

You can change any network parameters of DABin (or any Exemys Product) entering the Properties Dialog box.

To enter to the Properties Dialog box, select the device from the Devices List and then select the "Properties of..." command from "Devices" menu.

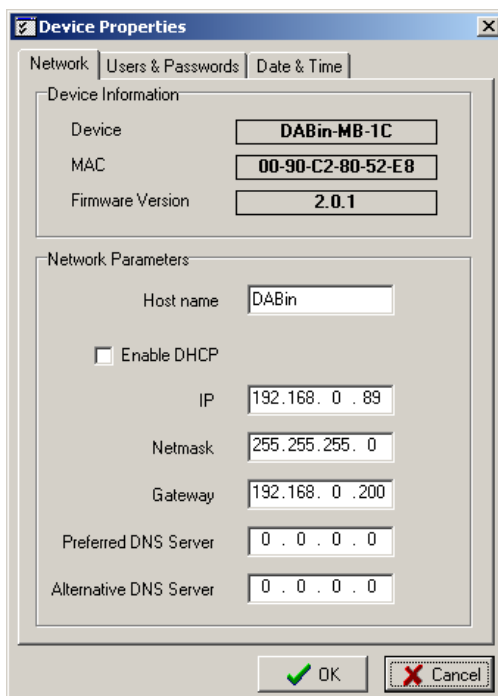

Figure 17 - DABin Network Properties Dialog box



TIP

The Properties Dialog box can be shown left clicking over the device in the Devices List and then selecting "Properties of..." from the contextual menu.

Once the Properties Dialog box is displayed, all network parameters can be entered:

**Host Name:** Device Name for identification purposes only. Enter a name for the device to distinguish it in the Devices List. This name is for identification only, not to access DABin's Web Server.

**Enable DHCP:** If the box is checked, DABin will search a DHCP at startup. If the LAN where DABin is connected to has a DHCP Server, check the box to make DABin acquire all network parameters automatically at startup.

**IP:** IP Address. Ask your Network administrator to assign DABin a static IP Address.

**Netmask:** Netmask of the local network.

**Gateway:** Default Gateway in the local network.

**Preferred DNS Server:** Default DNS Server IP Address. DABin uses this Server to resolve the SMTP Server name. This network parameter can be changed only if DABin is assigned an IP Address different than 0.0.0.0.

**Alternative DNS Server:** Alternative DNS Server IP Address. In the case that DABin couldn't resolve the SMTP Server name with the Default DNS Server, it will to resolve it with this alternative Server. Only can be changed when DABin is assigned an IP Address different than 0.0.0.0.



CAUTION

Some DHCP Servers not always assign the same IP Address to the same device. If DABin IP Address changes can be hard to find it from your Web Browser.

Change these Network configuration parameters and press "Ok" to configure DABin.

To enter the DNS Servers IP Addresses DABin must have assigned an IP Address different than 0.0.0.0. To configure DABin for the first time assign it an IP Address (static or by DHCP) and then enter the properties dialog box again to configure the DNS Servers IP Addresses.



Figure 18 - Administrator Password Dialog Box



NOTE

The Administrator Password is not enabled by default. If it is the first time DABin is configured left the password blank when DCM prompts for it.

DCM will prompt for the Administrator password to configure network parameters. In general, DCM will prompt for the Administrator password when trying to do any of the following tasks:

- Change DABin Network parameters.
- Change standard user name and its password.
- Change Administrator password.
- Connect to DABin to get or set general configuration or its internal Web Site.

Once the Administrator password is entered, DCM will configure DABin with the new network parameters.  
DABin will reset after changing these values. In a couple of seconds DABin will start working again with the new network parameters.

### 3.2.3 Device Locator

The Device Locator Application program is a small software installed with DCM. It is used for configuration of network parameters of all Exemys Products. Host name (identification), IP Address, Netmask and Gateway can be changed, but DNS Servers IP Addresses cannot be changed within Device Locator. You must know the DABin's Administrator password to change this parameters using the Device Locator.



TIP

**It doesn't matter if the device is not properly configured. If it is connected to the LAN, and working, Device Locator will find it.**

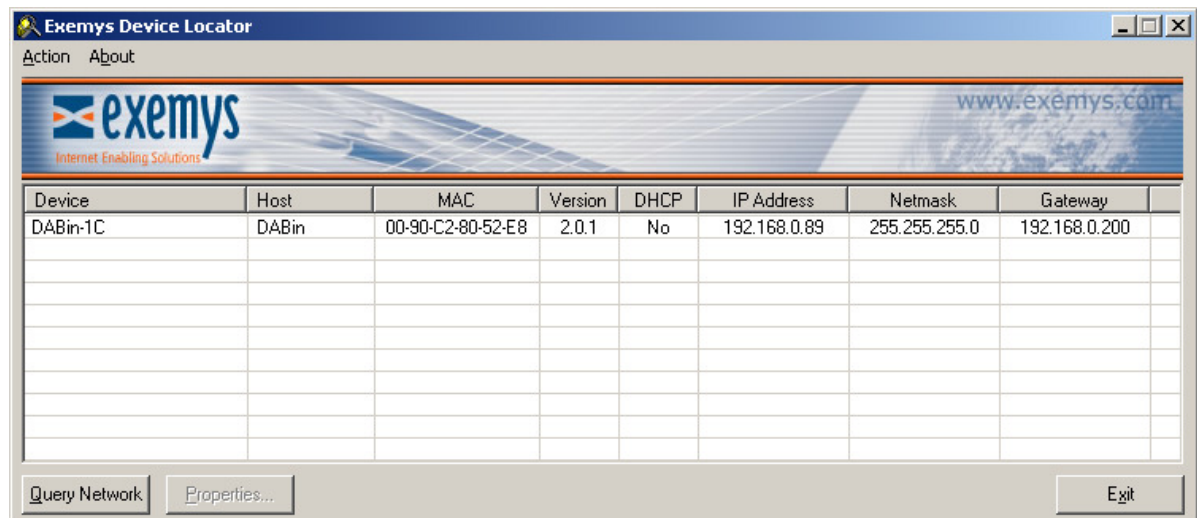

**Figure 19 - Device Locator Main window**

At startup, Device Locator searches for all Exemys devices connected to the LAN and shows them in the Devices List. If you want Device Locator to search devices again click the "Query Network" button to refresh.

Select the device from the Devices List to change its network parameters, and click the "Properties..." button to see the Properties dialog box of that device.

Change any of the network parameters as desired in the Properties dialog box and click "Ok" to configure it.



NOTE

**If the Device has an administrator password configured (enabled) it must be typed in the "Device Password" edit box before proceeding.**

**Figure 20 - Device Locator Properties Dialog box**

If Device Locator couldn't find a device, verify the following:

- If the device is turned on and it is connected to the network correctly.
- If the device is connected to the same LAN than that the PC running Device Locator is.

If Device Locator throws an error when trying to configure a device with new network parameters, verify the following:

- If the device is turned on and it is connected to the network correctly.
- If the Administrator password of the device has been typed correctly in the Properties dialog box.



ON THE WEB

**Check for the version of Device Locator selecting the "About" menu. Device Locator will show you a dialog box with the actual version. Enter our Web Site and get the latest version available at [www.exemys.com](http://www.exemys.com).**

### 3.2.4 ARP Table Method for IP Address Configuration

DABin IP Address is factory default to 0.0.0.0, which means that will search for a DHCP server at startup.

When turned on, the device tries to negotiate an IP Address with the DHCP Server for a maximum period of 10 seconds. Elapsed this period of time, if negotiation with DHCP Server failed, DABin

will try again 60 seconds later. This process will repeat indefinitely until a DHCP Server assigns DABin an IP Address or the user assigns DABin a static IP Address.

If you want to assign DABin a static IP Address, it could be assigned using the ARP Table method. At startup, during the first 7 seconds, DABin will wait for an IP Address configuration PING (ICMP). If the device receives a PING, with the destination IP Address different than that configured in DABin, it will take this destination IP Address, configure it, and reset with this new network parameter. After these 7 seconds, the device will answer the PING normally. Follow these steps to configure DABin with this method:

1. In Windows, add an entry in the ARP table of a PC in the same LAN DABin is, using the command:

```
arp -s 192.168.0.100 00-0B-FA-XX-XX-XX
```

In Unix, the command to add an entry to ARP table is:

```
arp -s 192.168.0.100 00:0B:FA:XX:XX:XX
```

Where 00-0B-FA-XX-XX-XX is the MAC of the device. The last 3 numbers depends on your Exemys device.

2. Send a PING to the IP Address just added to the ARP table with the command

```
ping 192.168.0.100 -t
```

the **-t** option sends the PING continuously.

3. Connect DABin to the network and turn it on. The PC will not receive answer of the PING, but at least a few seconds later.
4. When DABin starts answering the PING, it will have configured the new IP Address.

### 3.3 Security in DABin

---

#### 3.3.1 DABin's Security Scheme

To access the internal Web page in DABin, DABin configuration and DABin's FTP Server, a simple and effective security scheme is used.

Basically, DABin recognizes 3 users:

- **admin:** Is the Administrator user that has granted access to all configuration and internal FTP Server. Its name is fixed and it is admin. Only administrator password can be changed.
- **Standard user (user):** Is the user with granted access to internal DABin's Web site through a Web Browser. This user can be an SCADA operator and has access to see and change the Tag values. The standard user username and its password can both be changed.
- **anonymous:** Is the standard user with access to DABin's FTP server without a password, but it has read-only access to file system. The username "**anonymous**" cannot be changed.

**Table 7 - Users and their access to DABin**

User	Permission
admin	All DABin Configuration: Read and Write FTP Server for Web Site: Read and Write
Standard user	Web Site access through a Web Browser
anonymous	FTP Server Read-Only Access (no password)



CAUTION

**DABin is factory defaulted without an Administrator password. If this password is changed, don't forget it or lose it, because you will have to re enter the administrator password using the Serial Commands Console through RS-232 port.**

### 3.3.2 Changing Standard user Configuration

Standard user username and password can be changed as desired. Any standard Web browser will prompt for this username and password when trying to access DABin's Web Site, even if the standard user password is empty.

If standard user password is empty, but authentication is enabled then enter the standard user username and left the password empty when the Web browser prompts for it.

To change the standard user configuration (username and password), enter the Properties dialog box in DCM:

Open the Properties dialog box selecting the Device from the Devices List, and then selecting the command "Properties of..." from the "Devices" menu.

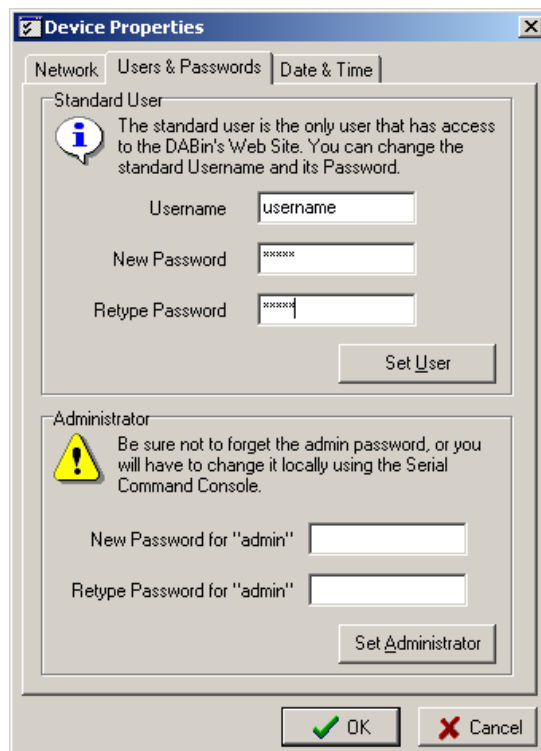

**Figure 21 - Users & Passwords in the Properties dialog box**

Select the "Users & Passwords" page in the Properties dialog box. DCM will send DABin a command to retrieve current configuration and will show it in the dialog box.  
In the "Username" edit box, enter the new username for the standard user.  
Enter the new standard user password twice in "New password" and "Retype password" edit boxes for DCM to verify the password is set properly.  
DCM will ask you for the current administrator password in order to change these parameters.



**Authentication in Web Server can be disabled if you left blank the field "Username". Then the Web browser will not prompt for any username and password when entering DABin's Web site.**

### 3.3.3 Changing Administrator Password (admin)

For administrator user (**admin**), only its password can be changed. This user has granted access to all DABin's configuration and to DABin's FTP server (read and write)  
You can leave DABin without an Administrator password, as is by default, but is recommendable to change the password for security reasons.

To change the Administrator password use the Properties Dialog box of the device:  
Open the Properties dialog box selecting the Device from the Devices List, and then selecting the command "Properties of..." from the "Devices" menu.  
Select the "Users & Passwords" page in the Properties dialog box. DCM will send DABin a command to retrieve current configuration and will show it in the dialog box.  
Enter the new Administrator password twice in "New password for admin" and "Retype password for admin" edit boxes for DCM to verify the password is set properly.  
Click on the "Set Administrator" button to configure the new password.  
DCM will ask you for the current administrator password in order to change this parameter.

## 3.4 Date and Time in DABin

When DABin sends e-mails informing the Alarm status of one of the Tags, it includes in the message body the date and time the alarm started.  
Date and Time are maintained by DABin and is constantly actualized even if it is turned off.

### 3.4.1 How to set up Date and Time in DABin

If the sending e-mail functionality of DABin is to be used is recommendable that Date and Time be synchronized.  
To synchronize date and time follow these steps:  
Open the Properties dialog box selecting the Device from the Devices List, and then selecting the command "Properties of..." from the "Devices" menu.  
Select the "Date & Time" page in the Properties dialog box. DCM will send DABin a command to retrieve current configuration and will show it in the dialog box.

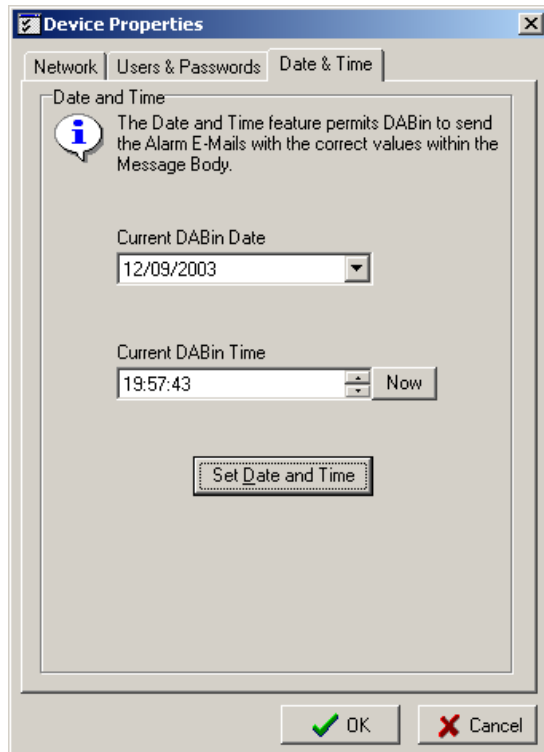

**Figure 22 - Date and Time in the Properties dialog box**

Enter current date and time in "Current DABin Date" and "Current DABin Time" respectively. The "Now" button will synchronize DABin's time with the PC. Click the "Set Date and Time" button to change to the values just entered.

# Chapter 4

## DABin Modbus Configuration

DABin Modbus acts as master, making queries to the slaves about the value of each Tag configured and sending the write queries triggered from DABin's Web page or Tag Monitor in DCM. In this chapter we will give the details to configure DABin Modbus to achieve these functions.



NOTE

The present Chapter information refers to DABin Modbus Model only. DABin Serial Protocol is not configurable.

### 4.1 How DABin Modbus Work

DABin Modbus is based in Read cycles, Write cycles and acknowledges of Tag Alarms. Each cycle starts with a wait of the Scan Time period, configured by user, and then sends the pending write queries, sets the pending acknowledgments of Tag Alarms and Reads the rest of the Tags.

In figure 23 is shown the complete Scan Cycle:

1. DABin waits for the Scan Time period: This time, configured by user, can be set from 0ms to 10000ms.

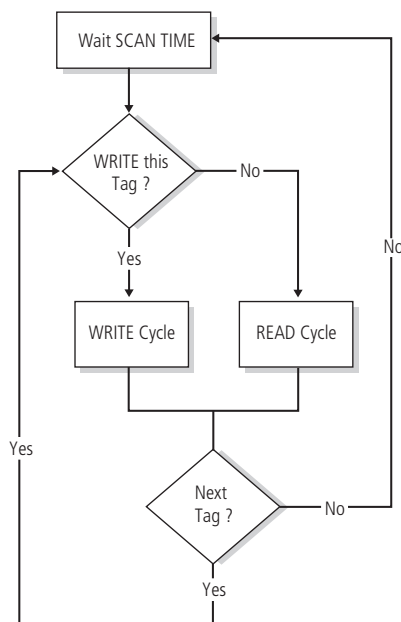

Figure 23 - Scan Cycle of DABin Modbus

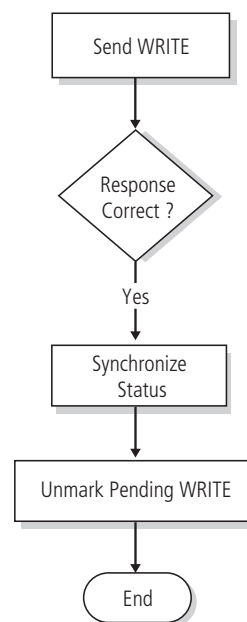
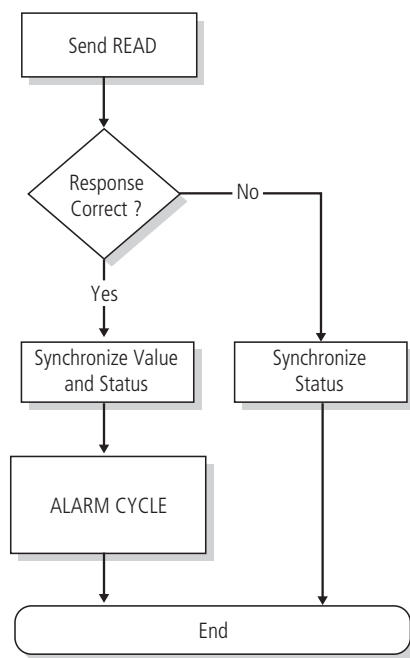

Figure 24 - Write Cycle in DABin Modbus

2. Reads Tag configuration and verifies if there is a pending Write operation for this Tag. If this is the case, it starts a Write Cycle, if not it starts a Read Cycle. This procedure is repeated for each Tag.
3. When all Tags are done, it starts back to 1.

The **Write Cycle** is particularly simple and consists basically in sending the Write query to the corresponding Modbus slave, synchronize Tag Status, and unmark the pending Write so as not to repeat the writing in further cycles. Figure 24 shows the complete Write Cycle.

The **Read Cycle** is like the Write one, but it differs because it includes an Alarm Control Cycle. Once the reading of the Tag has been successfully done, it synchronizes the Tag Value and Status, and then starts an Alarm Control Cycle. The Read Cycle is shown in Figure 25.



**Figure 25 - Read Cycle in DABin Modbus**

For DABin to start an Alarm Control Cycle for a Tag, this Tag must be Alarm-enabled in its configuration. If the Tag has its Alarm enabled, DABin maintains the Alarm Status for that Tag. Alarm Status can have any of the following values at a given time:

**In Alarm:** The Tag Value is in the Alarm condition, e.g. its value is in the defined Alarm range.

**Normal:** The Tag Value is not in the Alarm condition.

**Acknowledge:** The Tag Value is in the Alarm condition, but an operator has acknowledged this through a Web Browser.

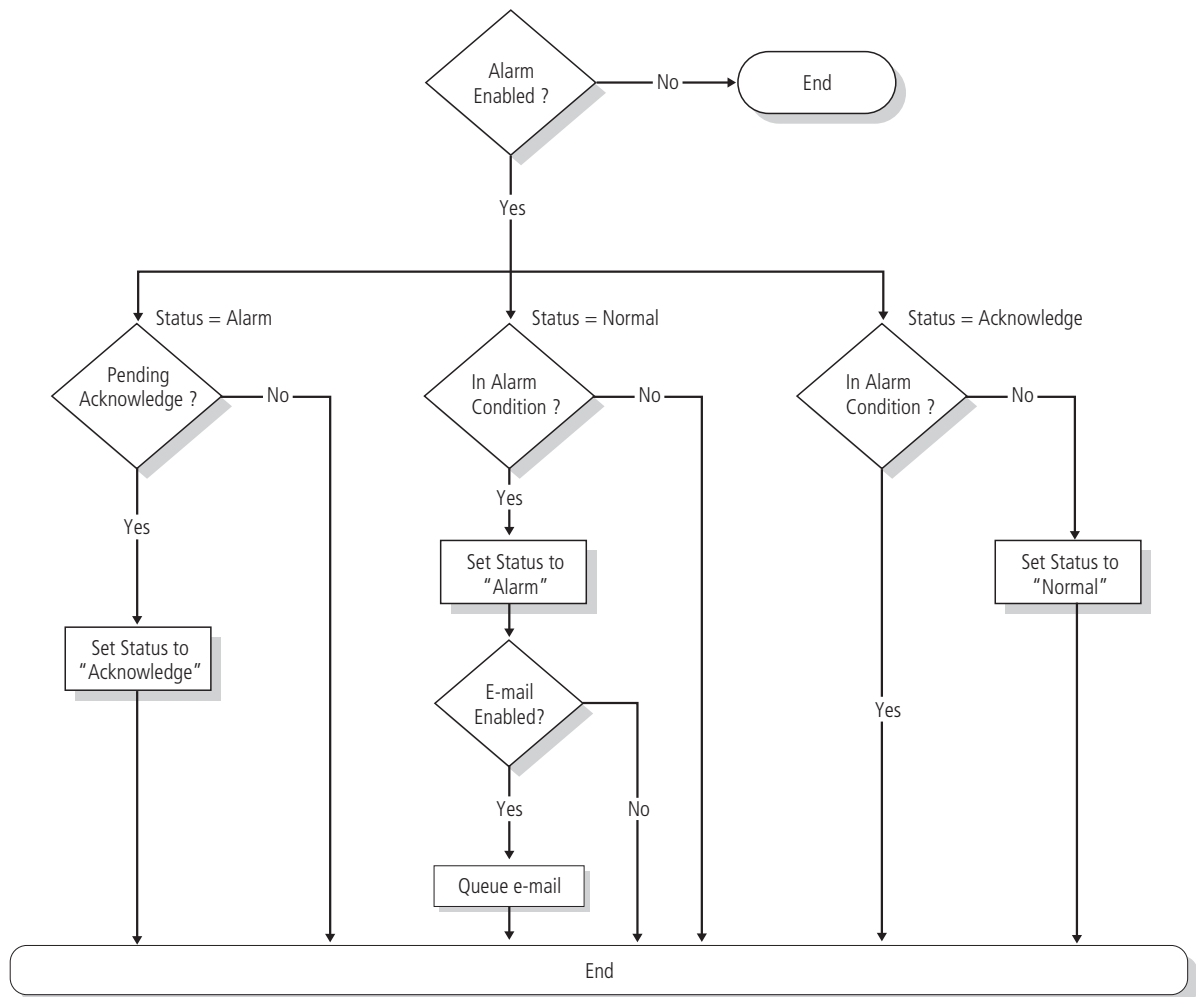

**Figure 26 - Alarm Control Cycle in DABin Modbus**

Basically, Alarm Control Cycle is:

1. If Tag is in *Alarm* State, DABin verifies if an operator has acknowledged this. If this is the case, Tag Alarm State is changed to *Acknowledged* for the next Read Cycle of this Tag.
2. If Tag is in *Normal/Alarm* State, DABin verifies if the value is in the Alarm condition. If so, it changes its Alarm State to *Alarm* and an e-mail to the internal e-mails queue is added if Tag if e-mail enabled.
3. If Tag is in *Acknowledged* Alarm State, DABin verifies if the Tag value is in Alarm condition. If so, the Alarm State remains unchanged, if not the Alarm State is changed to *Normal*.



NOTE

**The total time DABin spends in reading all configured Tags will depend on the total count of Tags and Scan Time period. If any of the Tags is not properly configured, and DABin receives no response from the Slave after the maximum time (Timeout), this time will be added to the total time the Scan Cycle takes. Set the Timeout and Scan Time parameters with caution following the instructions in this Manual.**

## 4.2 Creating a Modbus Configuration File

DCM administrates DABin's configuration files with **.dab** extension. A configuration file can be created or downloaded from a DABin for modification or back up.



TIP

**Several configuration .dab files can be saved with different configuration and send any of them at any given moment. Then DABin will reset and start working with the new configuration in just seconds.**

- ▶ See also: "Sending and Receiving Configuration" on page 44

To create a new configuration file follow these steps:

Select command "New" from "File" menu. The New File dialog box will appear to select the new file type to create.

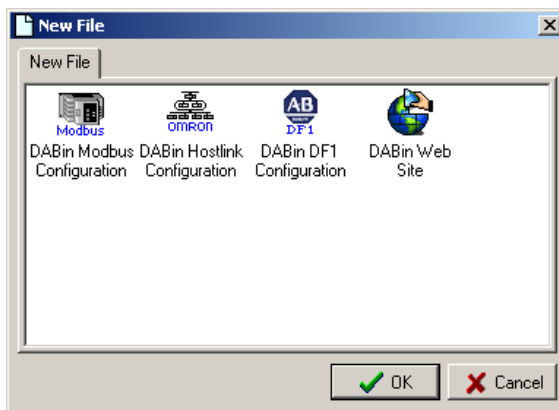

Figure 27 - New File dialog box

Select "DABin Modbus Configuration" from the list in the New File dialog box to create a new Modbus configuration file.

The new configuration file will be shown in the DCM Work area.



TIP

**When a file is modified but not yet saved, DCM will mark it with an asterisk (\*) besides the name of the file at the caption.**

## 4.3 Serial Port Configuration

In the case that Modbus Tags are going to be configured in DABin, the Serial Port must be configured correctly and coherently with configuration of the devices connected to DABin's Serial Port.

The Serial Port parameters are:

**Com Type:** This parameter has effect only in DABin models where the Serial Port is configurable. RS-232, RS-485 or RS-422 can be selected.

**Baud Rate (bps):** Is the transmission and reception rate of the Serial Port. Any value in the range 2400bps to 115200bps can be selected.

**Parity:** Is the Serial Port Parity. Select either, None (No parity), Odd (Odd parity) or Even (Even parity).

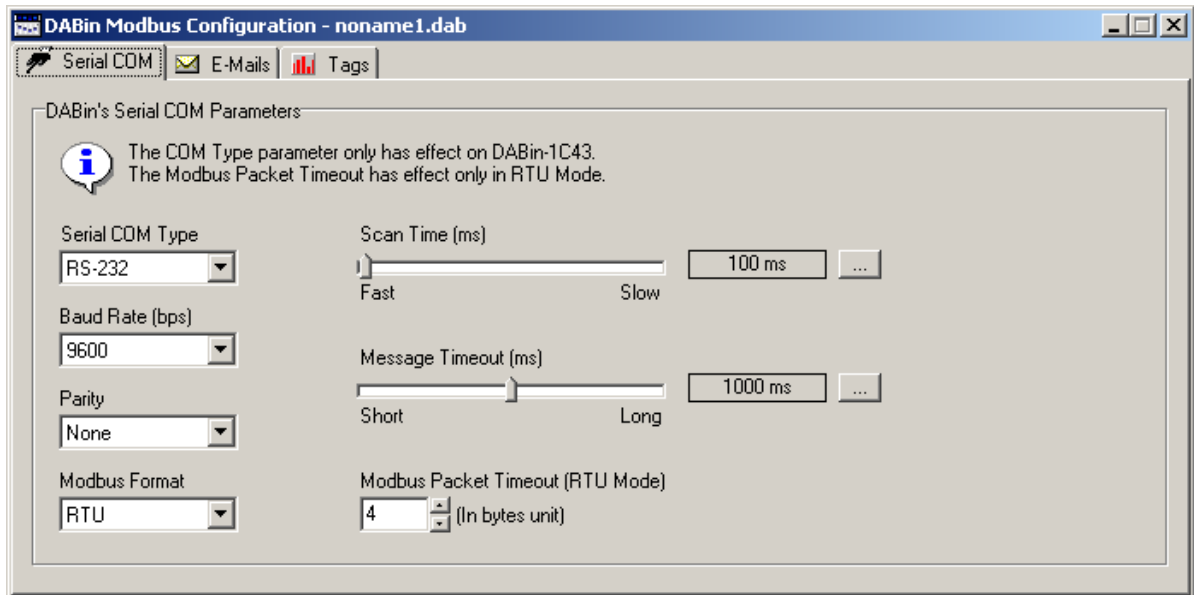

Figure 28 - Serial Port Configuration Page of DABin Modbus

**Modbus Format:** Is the Serial Modbus Format. Select ASCII or RTU depending on the device connected to DABin.

**Scan Time:** Is the delay time in milliseconds DABin will wait before starting a new Scan Cycle.

**ASCII Mode Maximum Response Timeout (*Message Timeout*):** In ASCII Mode, is the maximum time in milliseconds DABin will wait for a response from the slave. This parameter is ignored in RTU Mode.

**RTU Mode Maximum Response Timeout (*Packet Timeout*):** In RTU Mode, is the maximum time in bytes units DABin will wait for a response from the slave. This parameter is ignored in ASCII Mode.



TIP

The Scan Time and Message Timeout parameters can be entered manually, clicking the "..." button besides de track bar.

#### 4.4 E-Mail Configuration

DABin can send an e-mail when a Tag is in Alarm condition.

For this functionality to be available, all information to send e-mails must be given to DABin.

Each time a Tag enters the Alarm condition with the Alarm e-mail enabled, DABin will queue a message to be sent as fast as possible.

DABin messages queue can save up to 128 alarms at the same time. If DABin couldn't send messages for a wrong configuration and the queue becomes full, DABin will not add more messages until a place appears in the queue.



**DABin empties the Alarm messages queue at startup or reset. Verify that all messages have been send before changing configuration or before resetting the device manually.**

DABin's internal e-mail sending machine retries sending a message a number of times after a given period if the e-mail couldn't be send in a given time. All these parameters are configurable in DABin.

If DABin couldn't send an e-mail, it can be configured to:

Erase the message from the queue after it has tried to send it the number of times configured. Not to Erase the message and keep trying sending the message. This option can make a queue full if DABin is not correctly configured.

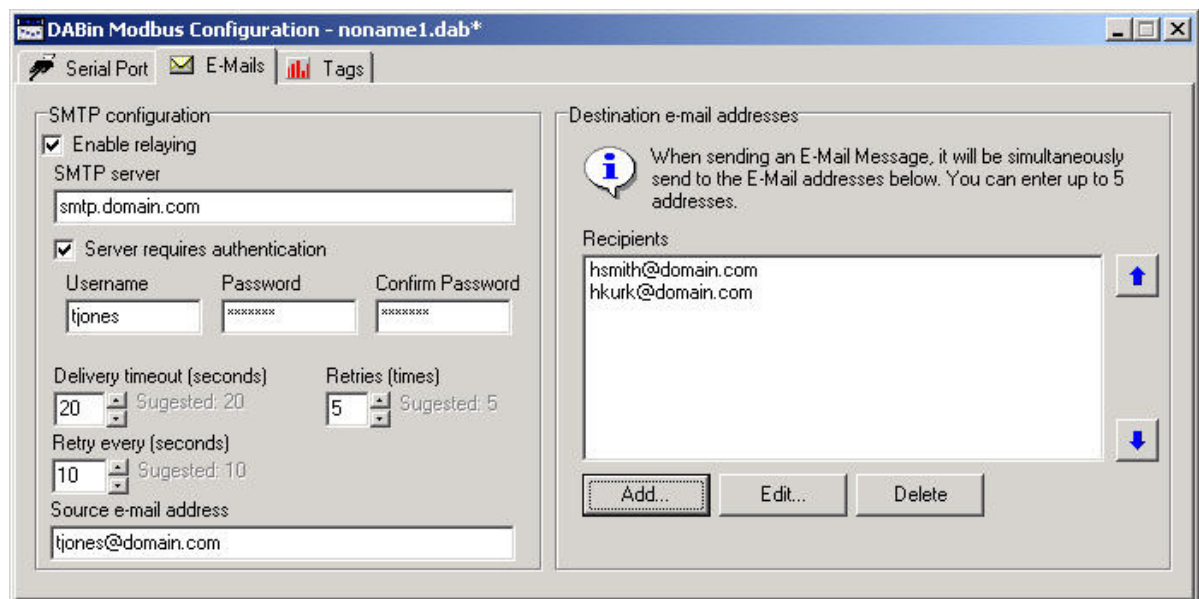

**Figure 29 - E-Mail configuration page of DABin Modbus**

E-Mail configuration is composed of the following:

**Enable relaying:** Mark the check box to enable e-mail relaying service.

**SMTP server:** Name or IP Address of SMTP server.

**Server requires authentication:** Check this option if the SMTP server needs User+Password authentication (plain text authentication). (\*)

**Username:** Name required for user authentication.

**Password:** Secret key required for user authentication.

**Confirm Password:** Retype of the secret key.

**Delivery timeout:** This is the maximum lapse (in seconds) DABin attempts to send an e-mail.

**Retries:** How many times DABin will try to send an e-mail before removing it from the queue. If this parameter is 0, DABin will keep trying to send it without erasing the message from the queue.

**Retry every (seconds):** Delay between retries.

**Source e-mail address:** Source address used for outgoing e-mails.

**Destination e-mail addresses:** An e-mail can be delivered to up to 5 different destinations. Add a new destination by clicking on the "Add" button. The "Edit" button can be used to change an e-

mail address, while the "Delete" button removes one destination from the list. Change the relaying priority by rearranging the list using the arrows on the right side: DABin relays e-mail from top to down.

(\*) This feature applies to firmware version 2.1 and higher.

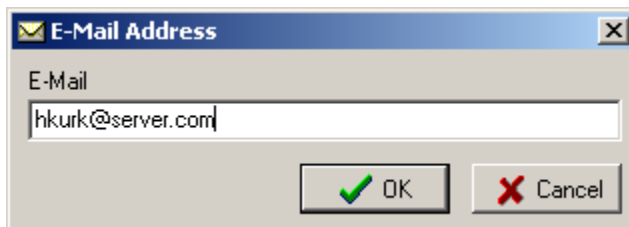

Figure 30 - E-Mail Address Edit Dialog box



CAUTION

For DABin to resolve the SMTP Server name correctly, at least one DNS IP Address must be properly configured. DABin will get the IP Address of the SMTP Server before sending e-mails. If no DNS Server IP Address is configured in DABin, SMTP Server IP Address must be entered explicitly. Ask your network administrator to obtain this information.

- ▶ See also: "Network Configuration Parameters" on page 22

## 4.5 Tags Configuration

DABin accept up to 128 different Tags. Tags in Modbus can be:

**Modbus Tags:** These are the Tags DABin will ask the Modbus slaves connected to the Serial Port (RS-232/485/422). They must contain the information needed to access the Modbus slave, e.g. Modbus Slave Address and Register Address.

**DABin's Digital Inputs Tags:** Digital Tags whose value is the mirror of the current state of one of DABin's input. Its configuration must contain the number of Digital Input and is exclusively read-only.

**DABin's Digital Outputs Tags:** Digital Tags whose value is the mirror of the current state of one of DABin's output. The operator can change this value and this change will be reflected in the corresponding DABin Digital Output.

**Internal Tags:** Special Digital Tags that provide information of status of serial communication and general alarm of the rest of the Tags. Can be included or not.



**Figure 32 - Modbus Tag Configuration**

To configure a Modbus Tag, enter the parameters described below:

**Source:** Select "Modbus Serial" to make a Modbus Tag. DABin will acquire the value from a slave connected to its Serial Port.

**Tag Name:** Enter the Name of the Tag. DABin will identify this Tag with its Name.

**Modbus Unit ID:** Is the Address or number of Modbus slave DABin will ask for the value of the Tag. Can be in the range 1 to 255.

**Tag Type:** Select the type of the Tag. In table 8 are shown all the types supported by DABin.



NOTE

**If a Tag is any of the Integer types but an scaling function of the value is configured, DABin will convert the type of Tag to Float.**

**Register Table:** Is the register table the required register for the Tag belongs to. *Holding Register*, *Input Register*, *Input Status* or *Coil Status* can be selected.



NOTE

**Registers in tables *Input Status* and *Coil Status* are Digital and "Single Bit" type must be selected for them. Also registers in tables *Input Status* and *Input Registers* must be declared as read-only.**

**Register Address:** Is the Address of the Modbus Register. Note that changing the Register Table changes the first digit in Register Address edit box. In table 9 are listed all the address ranges supported by DABin Modbus.

**Bit Position:** Is the Bit number (position) for the "Word Bit" type. A value between 0 and 15 can be entered, when 0 is the least significant bit.

**32 bit Register (Enron):** If Tag is representing a long integer (Long) or a floating point value (Float), then the way the slave uses this value can be changed. If the slave addresses just a 32-bit register for these types (Long and Float) then mark the check box. If the slave addresses 2 16-bit registers for Long and Float types, leave the check box unmarked.

**Table 8 - Types of Modbus Tags and its representation**

Type	Description	Range
Unsigned int	16-bit Unsigned Integer	0..65535
Signed int	16-bit Signed Integer	-32768..32767
Long	32-bit Signed Integer	-2147483648..2147483647
Long Inverted	32-bit Signed Integer. Modicon Format.	-2147483648..2147483647
Float	32-bit Float	-
Float Inverted	32-bit Float. Modicon Format.	-
BCD	16-bit BCD format	0000..9999
Word Bit	Bit in 16-bit Word	0, 1
Single Bit	Bit for Digital Input / Output, Coil or Input Status	0, 1

**Table 9 - Address Ranges in Modbus DABin**

Type	Range
Coil Status	000001..065536
Input Status	100001..165536
Input Register	300001..365536
Holding Register	400001..465536

### 4.5.3 Digital Inputs and Outputs Tags

Tags related with DABin's Digital Inputs/Outputs can be defined. Digital Inputs and Digital Outputs are both enumerated from 0.

- ▶ See also: "Inputs and Outputs" on page 15



CAUTION

The number of Digital Inputs and Outputs depends on the DABin Model. DABin will ignore Tags with Digital Inputs/Outputs that do not exist in the model in use.

**Figure 33 - Digital Inputs / Output Tag Configuration**

To configure a Tag related with DABin's Digital Inputs / Outputs:

**Source:** Select "Digital Input" or "Digital Outputs" to relate the Tag with DABin's Digital Inputs/Outputs.

**Tag Name:** Enter the Name of the Tag. DABin will identify this Tag with its Name.

**Bit Position:** Is the Input / Output number. Enter a value in the 0 to 7 range. First Input is the 0 input, and so as with the Outputs.



NOTE

**DABin's Digital Inputs Tags must be declared as read-only.**

#### 4.5.4 Internal Tags

DABin uses a set of internal Tags to give information about the general communication status with slaves and general Alarm status of the Tags. In Table 10 are listed all internal Tags supported by DABin.

**Table 10 - DABin Internal Tags**

Internal Tag	Description
_COMMERROR	Digital Tag. The value becomes 1 when a Serial Communication error is detected.
_ALARM	Digital Tag. The value becomes 1 when any Tag (Except Internal Tags) is in Alarm State, acknowledged or not
_ALARMNAK	Digital Tag. The value becomes 1 when any Tag (Except Internal Tags) is in Alarm State and has not been acknowledged by an operator.

To add an Internal Tag:

**Source:** Select "Internal" for the Tag to be updated by DABin internally.

**Tag Name:** Enter the name of the desired Internal Tag or click on the "... " button to see the Internal Tags lists. From the list select the Internal Tag and press "Ok".

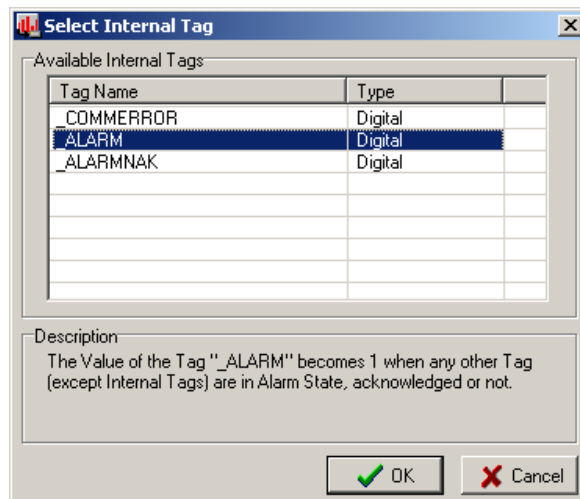

**Figure 34 - Internal Tag List**



TIP

**Enable Alarm and E-mail sending in Internal Tags to receive notification when DABin detects a failure in communication or any Tag enters the Alarm condition.**



NOTE

All Internal Tags must be declared as read-only.

#### 4.5.5 Value Writing Restrictions

Tags in DABin can be configured as write-enabled in a given range of values or read-only. This can be done from the Value Configuration Page in the Configuration Tag dialog box.



Figure 35 - Value Configuration Page

**Read only:** if the check box is marked DABin will not allow the operator to change the value of the Tag with a writing command from a Web browser.



NOTE

The Tags representing Digital Outputs cannot be declared as Read Only.

**Writing Limits:** marking the check box and entering the Minimum and Maximum values allowed for writing, DABin will allow an operator to write a value into this range.

#### 4.5.6 Tag Alarm Configuration

To make DABin control the Alarm status of a Tag, the Tag must have its Alarm enabled.

- ▶ See also: "How DABin Modbus Works" on page 31

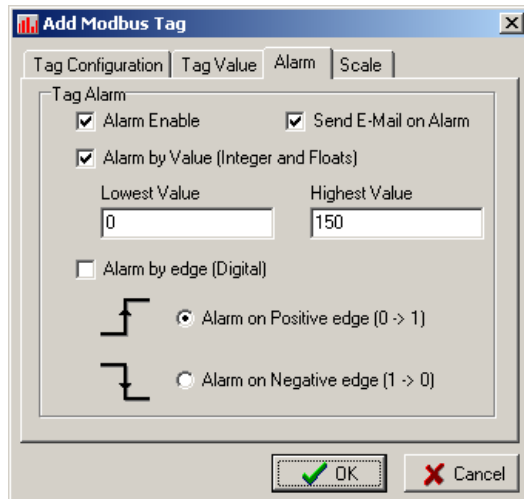

Figure 36 - Alarm Configuration Page

Alarms in DABin can be triggered by a range of values on analog Tags (Integers or Floats), or by detection of an edge in Digital Tags (Inputs/Outputs, Internal Tags, Word Bit or Single Bit).

**Alarm Enable:** To enable the Alarm for this Tag just mark the check box.

**Send E-Mail on Alarm:** If marked, DABin will queue an e-mail message when the Tag value enters the Alarm condition.

**If Tag is Analog** (Integer or Floating Point), mark the "Alarm by value" check box and then enter the Minimum and Maximum values for the Alarm. DABin will evaluate if the value is in that range after each Read Cycle, and if not the Alarm will be triggered.

**If Tag is Digital** (Inputs/Outputs, Internal Tags, Word Bit or Single Bit), mark the check box "Alarm by edge" and then select either, "Alarm on Positive edge" or "Alarm on Negative edge" as desired.

#### 4.5.7 Tag Value Scaling

DABin can acquire a value and make a simple calculation before assigning it to the Tag value. This is helpful for scaling factors and other simple calculations.

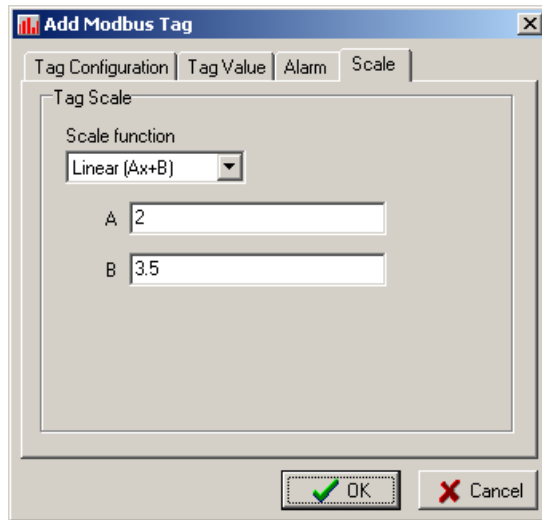

**Figure 37 - Scale configuration page**

DABin supports the Linear ( $Y=Ax+B$ ) function, where  $x$  is the acquired value and  $Y$  will be the Tag value. DCM allows to configure both A and B factors.



NOTE

### Digital Tags are not scalable.

For the DABin to make the calculation on the acquired value select Linear ( $Ax+B$ ) as the scale function.

Enter values A and B. Floating point numbers can be entered for these factors.



NOTE

**If Tag has Minimum and Maximum writing limits and it is scaled, DABin will understand those limits as already scaled using the same factors and function, so as with the Alarm Limits. In general Writing Limits and Alarm Limits are referred to the Tag value and not the acquired value.**

## 4.6 Sending and Receiving Configuration

Once configuration is complete, you can save it in a **.dab** file and send it to DABin. Upon receiving the configuration, DABin will reset itself and start working with the new configuration.

First connect to DABin using DCM and then transmit the new configuration or receive current DABin's configuration.

### 4.6.1 Connecting to DABin using DCM

Before sending or receiving any configuration file or the Web Site, you have to connect to DABin. DCM will prompt for the Administrator password before connecting.

To Connect to DABin follow these steps:

Select the DABin from the Devices List at the bottom of the DCM Window.

Select "Connect" from the "Devices" menu.

DCM will prompt for the administrator password. Enter the password or left the box blank if no password has been configured for DABin Administrator, then click on the "Ok" button.



NOTE

**DCM uses HTTP protocol for communication with DABin. Check for DCM configuration for a HTTP Proxy server if you cannot find a DABin or connect to it.**

#### 4.6.2 Sending and Receiving Configuration

Once connected to a DABin you can receive current configuration or send any configuration **.dab** file to it.

**To Receive** Configuration from a connected DABin:

Select the command "Get from DABin..." from the "Configuration" menu.

The Get Configuration dialog box will appear starting transfer automatically.

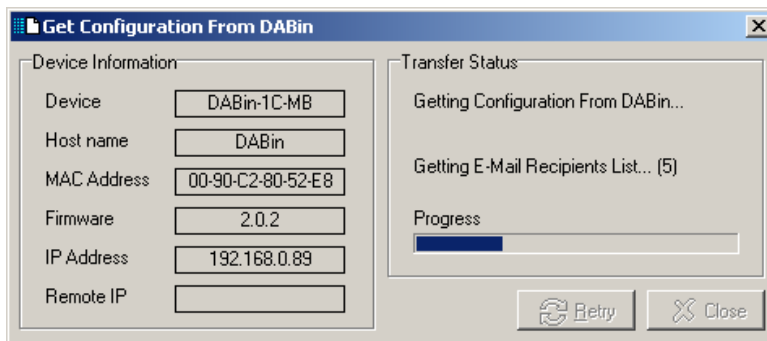

**Figure 38 - Receiving Configuration from DABin**

When the transfer is complete click on the "Close" button. DCM will create a new configuration window with the just transferred configuration data.

**To Send** Configuration to a connected DABin:

Select the desired configuration window to transfer to DABin.

Select the command "Send to DABin..." from the "Configuration" menu.

The Send Configuration dialog box will appear showing the transfer status.

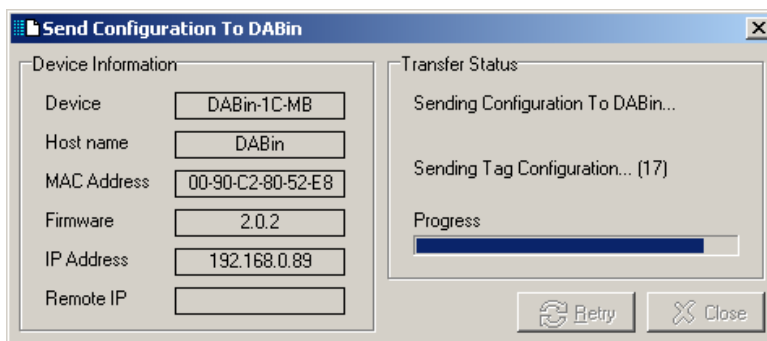

**Figure 39 - Sending Configuration to Connected DABin**

# Chapter 5

## DABin Hostlink Configuration

DABin Hostlink acts as master, making queries to the slaves about the value of each Tag configured and sending the write queries triggered from DABin's Web page or Tag Monitor in DCM. In this chapter we will give the details to configure DABin Hostlink to achieve these functions.



NOTE

The present Chapter information refers to DABin Hostlink Model only. DABin Serial Protocol is not configurable.

### 5.1 How DABin Hostlink Work

DABin Hostlink is based in Read cycles, Write cycles and acknowledges of Tag Alarms. Each cycle starts with a wait of the Scan Time period, configured by user, and then sends the pending write queries, sets the pending acknowledgments of Tag Alarms and Reads the rest of the Tags.

In figure 40 is shown the complete Scan Cycle:

1. DABin waits for the Scan Time period: This time, configured by user, can be set from 0ms to 10000ms.

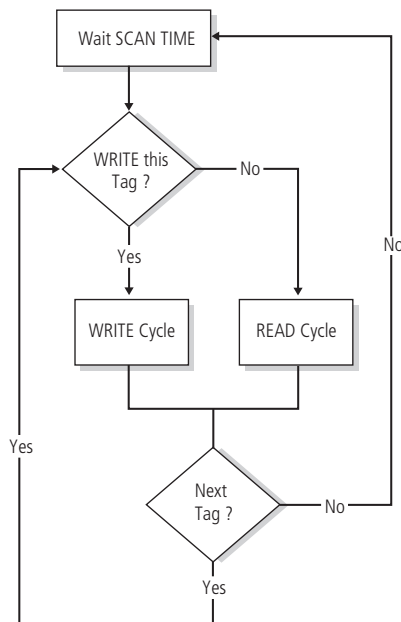

Figure 40 - Scan Cycle of DABin Hostlink

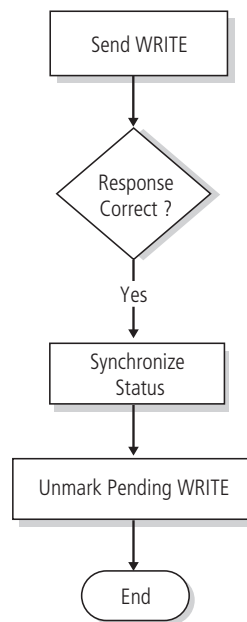
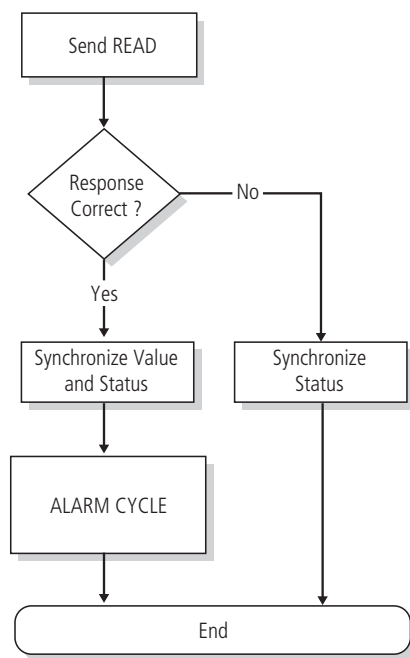

Figure 41 - Write Cycle of DABin Hostlink

2. Reads Tag configuration and verifies if there is a pending Write operation for this Tag. If this is the case, it starts a Write Cycle, if not it starts a Read Cycle. This procedure is repeated for each Tag.
3. When all Tags are done, it starts back to 1.

The **Write Cycle** is particularly simple and consists basically in sending the Write query to the corresponding Hostlink slave, synchronize Tag Status, and unmark the pending Write so as not to repeat the writing in further cycles. Figure 41 shows the complete Write Cycle.

The **Read Cycle** is like the Write one, but it differs because it includes an Alarm Control Cycle. Once the reading of the Tag has been successfully done, it synchronizes the Tag Value and Status, and then starts an Alarm Control Cycle. The Read Cycle is shown in Figure 42.



**Figure 42 - Read Cycle of DABin Hostlink**

For DABin to start an Alarm Control Cycle for a Tag, this Tag must be Alarm-enabled in its configuration. If the Tag has its Alarm enabled, DABin maintains the Alarm Status for that Tag. Alarm Status can have any of the following values at a given time:

**In Alarm:** The Tag Value is in the Alarm condition, e.g. its value is in the defined Alarm range.

**Normal:** The Tag Value is not in the Alarm condition.

**Acknowledge:** The Tag Value is in the Alarm condition, but an operator has acknowledged this through a Web Browser.

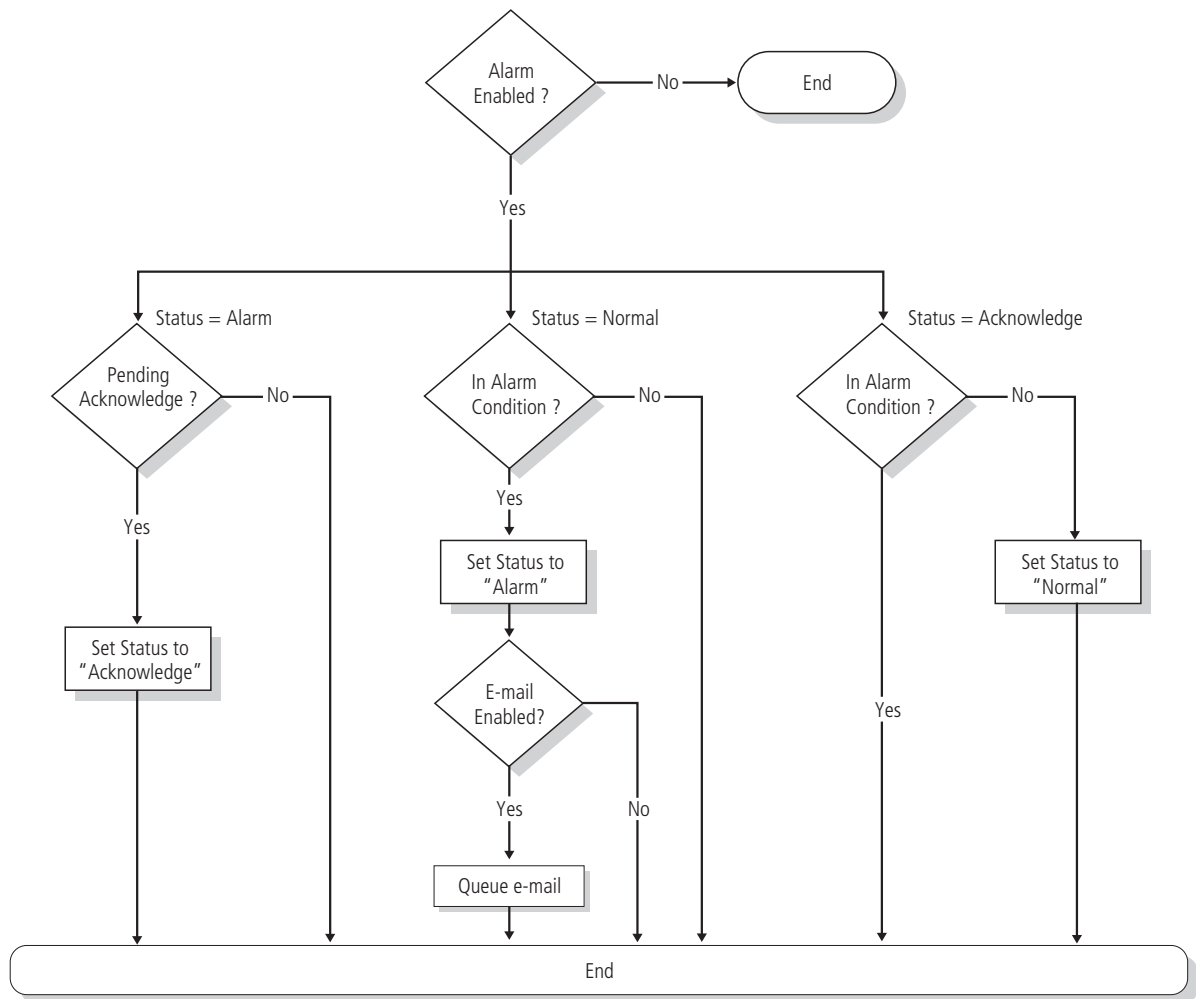

**Figure 43 - Alarm Control Cycle of DABin Hostlink**

Basically, Alarm Control Cycle is:

4. If Tag is in *Alarm* State, DABin verifies if an operator has acknowledged this. If this is the case, Tag Alarm State is changed to *Acknowledged* for the next Read Cycle of this Tag.
5. If Tag is in *Normal/Alarm* State, DABin verifies if the value is in the Alarm condition. If so, it changes its Alarm State to *Alarm* and an e-mail to the internal e-mails queue is added if Tag if e-mail enabled.
6. If Tag is in *Acknowledged* Alarm State, DABin verifies if the Tag value is in Alarm condition. If so, the Alarm State remains unchanged, if not the Alarm State is changed to *Normal*.



NOTE

**The total time DABin spends in reading all configured Tags will depend on the total count of Tags and Scan Time period. If any of the Tags is not properly configured, and DABin receives no response from the Slave after the maximum time (Timeout), this time will be added to the total time the Scan Cycle takes. Set the Timeout and Scan Time parameters with caution following the instructions in this Manual.**

## 5.2 Creating a Hostlink Configuration File

DCM administrates DABin's configuration files with **.dab** extension. A configuration file can be created or downloaded from a DABin for modification or back up.



TIP

**Several configuration .dab files can be saved with different configuration and send any of them at any given moment. Then DABin will reset and start working with the new configuration in just seconds.**

- ▶ See also: "Sending and Receiving Configuration" on page 58

To create a new configuration file follow these steps:

Select command "New" from "File" menu. The New File dialog box will appear to select the new file type to create.

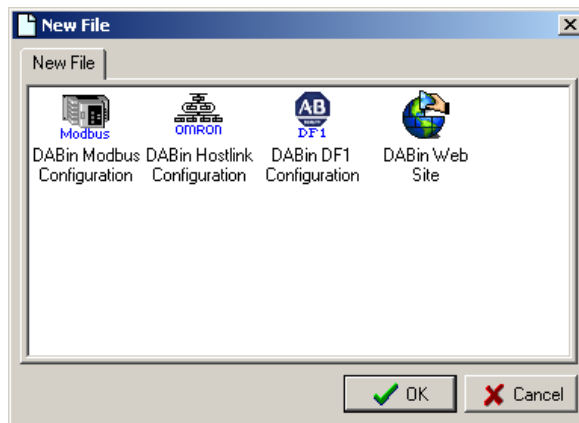

Figure 44 - New File dialog box

Select "DABin Hostlink Configuration" from the list in the New File dialog box to create a new Hostlink configuration file.

The new configuration file will be shown in the DCM Work area.



TIP

**When a file is modified but not yet saved, DCM will mark it with an asterisk (\*) besides the name of the file at the caption.**

## 5.3 Serial Port Configuration

In the case that Hostlink Tags are going to be configured in DABin, the Serial Port must be configured correctly and coherently with configuration of the devices connected to DABin's Serial Port.

The Serial Port parameters are:

**Com Type:** This parameter has effect only in DABin models where the Serial Port is configurable. RS-232, RS-485 or RS-422 can be selected.

**Baud Rate (bps):** Is the transmission and reception rate of the Serial Port. Any value in the range 2400bps to 115200bps can be selected.

**Parity:** Is the Serial Port Parity. Select either, None (No parity), Odd (Odd parity) or Even (Even parity).

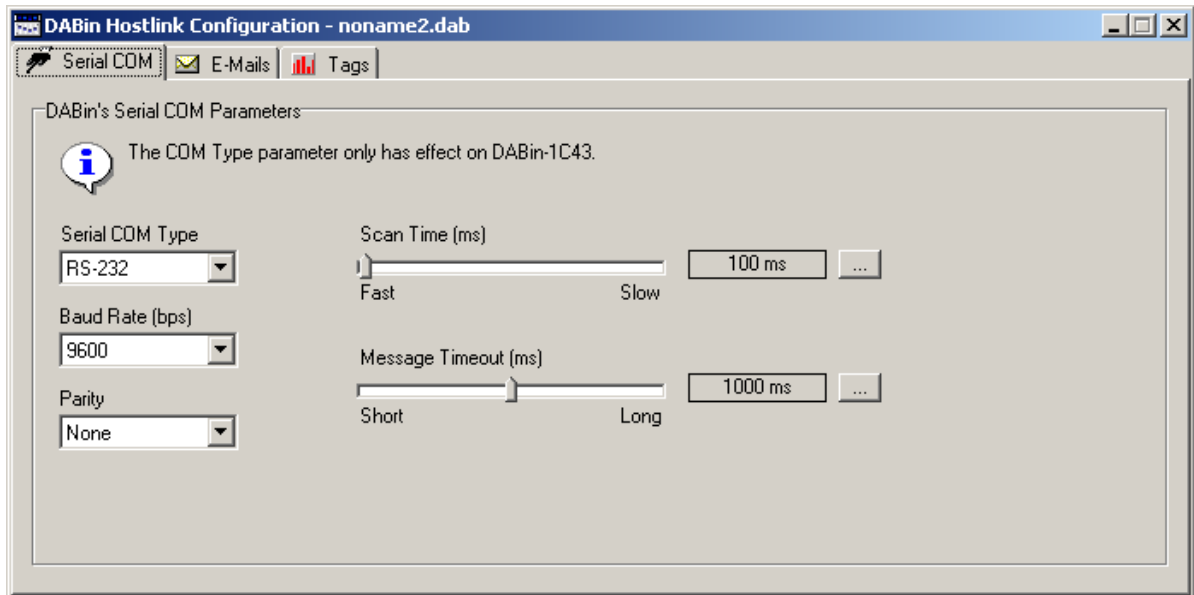

Figure 45 - Serial Port Configuration Page for DABin Hostlink

**Scan Time:** Is the delay time in milliseconds DABin will wait before starting a new Scan Cycle.

**Maximum Response Timeout (*Message Timeout*):** Is the maximum time in milliseconds DABin will wait for a response from the slave.



TIP

The Scan Time and Message Timeout parameters can be entered manually, clicking the "..." button besides the track bar.

## 5.4 E-Mail Configuration

DABin can send an e-mail when a Tag is in Alarm condition.

For this functionality to be available, all information to send e-mails must be given to DABin.

Each time a Tag enters the Alarm condition with the Alarm e-mail enabled, DABin will queue a message to be sent as fast as possible.

DABin messages queue can save up to 128 alarms at the same time. If DABin couldn't send messages for a wrong configuration and the queue becomes full, DABin will not add more messages until a place appears in the queue.



CAUTION

DABin empties the Alarm messages queue at startup or reset. Verify that all messages have been sent before changing configuration or before resetting the device manually.

DABin's internal e-mail sending machine retries sending a message a number of times after a given period if the e-mail couldn't be sent in a given time. All these parameters are configurable in DABin.

If DABin couldn't send an e-mail, it can be configured to:  
 Erase the message from the queue after it has tried to send it the number of times configured.  
 Not to Erase the message and keep trying sending the message. This option can make a queue full if DABin is not correctly configured.

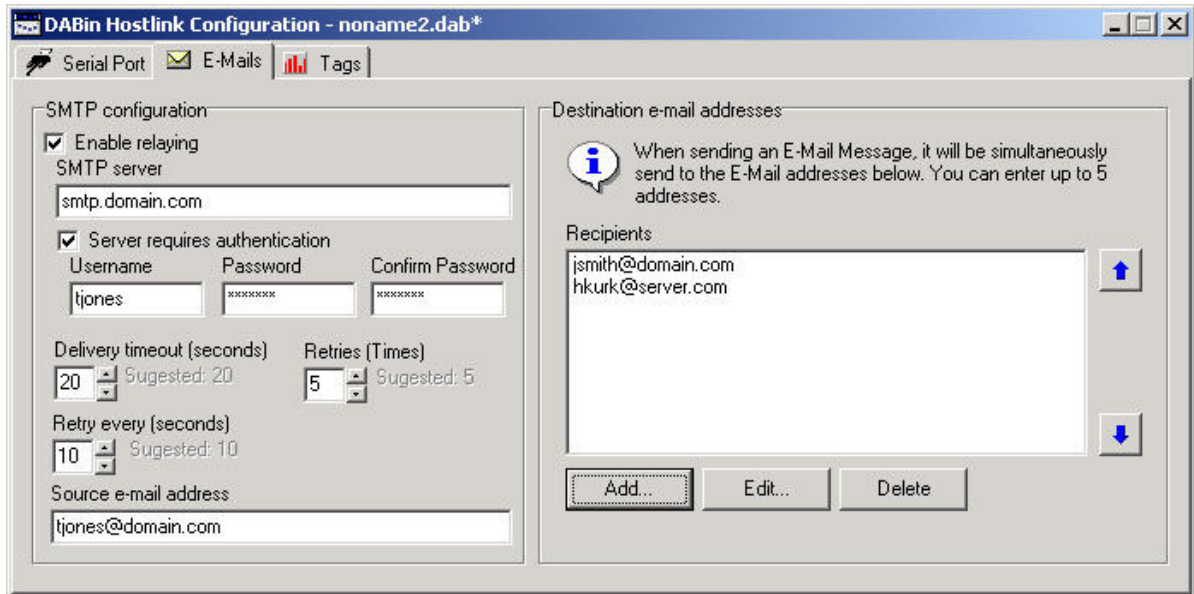

Figure 46 - E-Mail configuration page of DABin Hostlink

E-Mail configuration is composed of the following:

**Enable relaying:** Mark the check box to enable e-mail relaying service.

**SMTP server:** Name or IP Address of SMTP server.

**Server requires authentication:** Check this option if the SMTP server needs User+Password authentication (plain text authentication). (\*)

**Username:** Name required for user authentication.

**Password:** Secret key required for user authentication.

**Confirm Password:** Retype of the secret key.

**Delivery timeout:** This is the maximum lapse (in seconds) DABin attempts to send an e-mail.

**Retries:** How many times DABin will try to send an e-mail before removing it from the queue. If this parameter is 0, DABin will keep trying to send it without erasing the message from the queue.

**Retry every (seconds):** Delay between retries.

**Source e-mail address:** Source address used for outgoing e-mails.

**Destination e-mail addresses:** An e-mail can be delivered to up to 5 different destinations. Add a new destination by clicking on the "Add" button. The "Edit" button can be used to change an e-mail address, while the "Delete" button removes one destination from the list. Change the relaying priority by rearranging the list using the arrows on the right side: DABin relays e-mail from top to down.

(\*) This feature applies to firmware version 2.1 and higher.

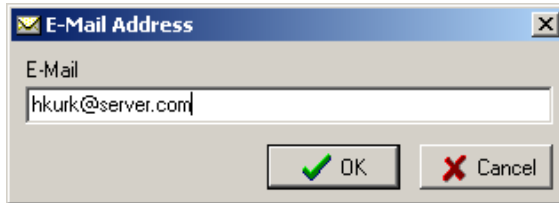

Figure 47 - E-Mail Address Edit Dialog box



CAUTION

For DABin to resolve the SMTP Server name correctly, at least one DNS IP Address must be properly configured. DABin will get the IP Address of the SMTP Server before sending e-mails. If no DNS Server IP Address is configured in DABin, SMTP Server IP Address must be entered explicitly. Ask your network administrator to obtain this information.

▶ See also: "Network Configuration Parameters" on page 22

## 5.5 Tags Configuration

DABin accept up to 128 different Tags. Tags can be:

**Hostlink Tags:** These are the Tags DABin will ask the Hostlink slaves connected to the Serial Port (RS-232/485/422). They must contain the information needed to access the Hostlink slave, e.g. Hostlink Slave Address and Register Address.

**DABin's Digital Inputs Tags:** Digital Tags whose value is the mirror of the current state of one of DABin's input. Its configuration must contain the number of Digital Input and is exclusively read-only.

**DABin's Digital Outputs Tags:** Digital Tags whose value is the mirror of the current state of one of DABin's output. The operator can change this value and this change will be reflected in the corresponding DABin Digital Output.

**Internal Tags:** Special Digital Tags that provide information of status of serial communication and general alarm of the rest of the Tags. Can be included or not.

Name	Source	Unit ID	Table	Address	Type	Bit Pos	Read Only	Limits	Min	Max
ANALOG	Hostlink Serial	0	IR	1	Unsigned int	0	No	No	0	0
TEMPERAT...	Hostlink Serial	1	IR	2	Unsigned int	0	No	No	0	0

Figure 48 - Tags Page configuration for DABin Hostlink

In general, any Tag configuration includes:

**General Configuration:** Where DABin will search for Tag value, slave information (if it is a Hostlink Tag) and the Type of the Tag.

**Tag writing restrictions:** If the Tag is read-only or not, or if the written value must be in a given range.

**Alarm Configuration:** If the Tag is going to be Alarm-enabled and its Alarm condition, and if DABin must send an e-mail to all destination addresses when the alarm condition is detected.

**Scale:** DABin can make a simple calculation with the acquired value. The result of this calculation is the value of the Tag that will be seen by the operator.

### 5.5.1 Tags Administration

Tags can be added, edited or deleted from the list that will be sent to a DABin. In the Tags Page in the configuration file the complete list of Tags with all configuration can be seen.

**To add a new Tag:** Select command "Add Tag..." from "Configuration" menu. The New Tag dialog box will appear.

**To edit an existing Tag:** Select the Tag to edit in the List, then select "Edit Tag..." from "Configuration" menu. The Edit Tag dialog box will appear with current Tag configuration.

**To Delete a Tag:** Select the Tag to delete from the Tags List, then select command "Remove Tag" from "Configuration" menu. DCM will ask for confirmation before deleting the Tag.

### 5.5.2 Hostlink Tags Configuration

The Hostlink Tags are the Tags whose value will be searched by DABin using the Serial Port.

Figure 49 - Hostlink Tag Configuration

To configure a Hostlink Tag, enter the parameters described below:

**Source:** Select "Hostlink Serial" to make a Hostlink Tag. DABin will acquire the value from a slave connected to its Serial Port.

**Tag Name:** Enter the Name of the Tag. DABin will identify this Tag with its Name.

**Hostlink Unit ID:** Is the Address or number of Hostlink slave DABin will ask for the value of the Tag. Can be in the range 1 to 255.

**Tag Type:** Select the type of the Tag. In table 8 are shown all the types supported by DABin.



NOTE

**If a Tag is any of the Integer types but an scaling function of the value is configured, DABin will convert the type of Tag to Float.**

**Register Table:** Is the register table the required register for the Tag belongs to. *IR/SR, LR, HR, TCPV* or *DM* can be selected.

**Register Address:** Is the Address of the Hostlink Register. An Address in the range 0000 to 9999 can be entered.

**Bit Position:** Is the Bit number (position) for the "Word Bit" type. A value between 0 and 15 can be entered, when 0 is the least significant bit.

**Table 11 - Types of Hostlink Tags and its representation**

Type	Description	Range
Unsigned int	16-bit Unsigned Integer	0..65535
Signed int	16-bit Signed Integer	-32768..32767
Long	32-bit Signed Integer	-2147483648..2147483647
Float	32-bit Float	-
BCD	16-bit BCD format	0000..9999
Word Bit	Bit in 16-bit Word	0, 1
Single Bit	Only for DABin's Digital I/O	0, 1

### 5.5.3 Digital Inputs and Outputs Tags

Tags related with DABin's Digital Inputs/Outputs can be defined. Digital Inputs and Digital Outputs are both enumerated from 0.

- ▶ See also: "Inputs and Outputs" on page 15



CAUTION

**The number of Digital Inputs and Outputs depends on the DABin Model. DABin will ignore Tags with Digital Inputs/Outputs that do not exist in the model in use.**

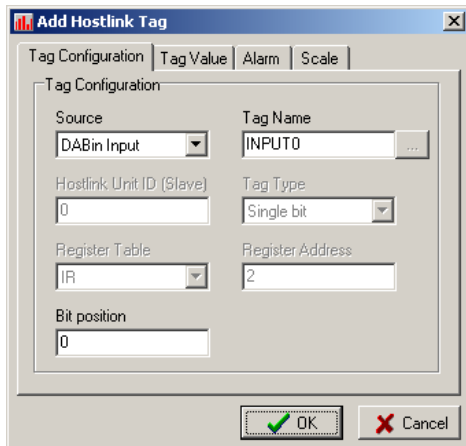

Figure 50 - Digital Inputs / Output Tag Configuration

To configure a Tag related with DABin's Digital Inputs / Outputs:

**Source:** Select "Digital Input" or "Digital Outputs" to relate the Tag with DABin's Digital Inputs/Outputs.

**Tag Name:** Enter the Name of the Tag. DABin will identify this Tag with its Name.

**Bit Position:** Is the Input / Output number. Enter a value in the 0 to 7 range. First Input is the 0 input, and so as with the Outputs.



NOTE

**DABin's Digital Inputs Tags must be declared as read-only.**

### 5.5.4 Internal Tags

DABin uses a set of internal Tags to give information about the general communication status with slaves and general Alarm status of the Tags. In Table 10 are listed all internal Tags supported by DABin.

Table 12 - DABin Internal Tags

Internal Tag	Description
_COMMERROR	Digital Tag. The value becomes 1 when a Serial Communication error is detected.
_ALARM	Digital Tag. The value becomes 1 when any Tag (Except Internal Tags) is in Alarm State, acknowledged or not
_ALARMNAK	Digital Tag. The value becomes 1 when any Tag (Except Internal Tags) is in Alarm State and has not been acknowledged by an operator.

To add an Internal Tag:

**Source:** Select "Internal" for the Tag to be updated by DABin internally.

**Tag Name:** Enter the name of the desired Internal Tag or click on the "..." button to see the Internal Tags lists. From the list select the Internal Tag and press "Ok".

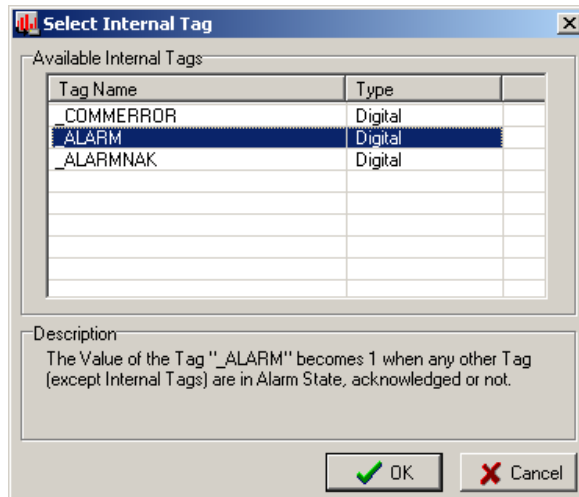

Figure 51 - Internal Tag List



TIP

Enable Alarm and E-mail sending in Internal Tags to receive notification when DABin detects a failure in communication or any Tag enters the Alarm condition.



NOTE

All Internal Tags must be declared as read-only.

### 5.5.5 Value Writing Restrictions

Tags in DABin can be configured as write-enabled in a given range of values or read-only. This can be done from the Value Configuration Page in the Configuration Tag dialog box.

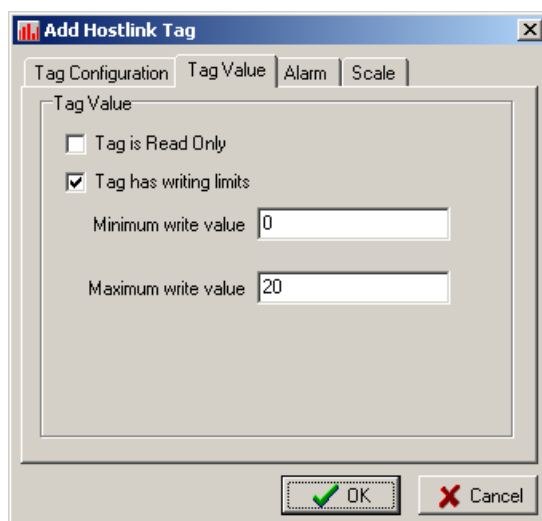

Figure 52 - Value Configuration Page

**Read only:** if the check box is marked DABin will not allow the operator to change the value of the Tag with a writing command from a Web browser.



NOTE

**The Tags representing Digital Outputs cannot be declared as Read Only.**

**Writing Limits:** marking the check box and entering the Minimum and Maximum values allowed for writing, DABin will allow an operator to write a value into this range.

### 5.5.6 Tag Alarm Configuration

To make DABin control the Alarm status of a Tag, the Tag must have its Alarm enabled.

- ▶ See also: "How DABin Hostlink Work" on page 46

Alarms in DABin can be triggered by a range of values on analog Tags (Integers or Floats), or by detection of an edge in Digital Tags (Inputs/Outputs, Internal Tags or Word Bit).

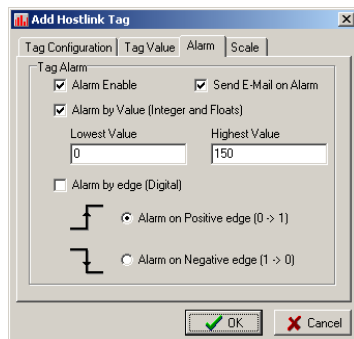

Figure 53 - Alarm Configuration Page

**Alarm Enable:** To enable the Alarm for this Tag just mark the check box.

**Send E-Mail on Alarm:** If marked, DABin will queue an e-mail message when the Tag value enters the Alarm condition.

**If Tag is Analog** (Integer or Floating Point), mark the "Alarm by value" check box and then enter the Minimum and Maximum values for the Alarm. DABin will evaluate if the value is in that range after each Read Cycle, and if not the Alarm will be triggered.

**If Tag is Digital** (Inputs/Outputs, Internal Tags, Word Bit or Single Bit), mark the check box "Alarm by edge" and then select either, "Alarm on Positive edge" or "Alarm on Negative edge" as desired.

### 5.5.7 Tag Value Scaling

DABin can acquire a value and make a simple calculation before assign it to the Tag value. This is helpful for scaling factors and other simple calculation.

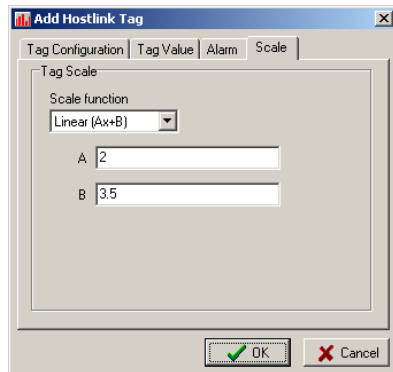

**Figure 54 - Scale configuration page**

DABin supports the Linear ( $Y=Ax+B$ ) function, where  $x$  is the acquired value and  $Y$  will be the Tag value. DCM allows to configure both A and B factors.



NOTE

### Digital Tags are not scalable.

For the DABin to make the calculation on the acquired value select Linear ( $Ax+B$ ) as the scale function.

Enter values A and B. Floating point numbers can be entered for these factors.



NOTE

**If Tag has Minimum and Maximum writing limits and it is scaled, DABin will understand those limits as already scaled using the same factors and function, so as with the Alarm Limits. In general Writing Limits and Alarm Limits are referred to the Tag value and not the acquired value.**

## 5.6 Sending and Receiving Configuration

Once configuration is complete, you can save it in a **.dab** file and send it to DABin. Upon receiving the configuration, DABin will reset itself and start working with the new configuration.

First connect to DABin using DCM and then transmit the new configuration or receive current DABin's configuration.

### 5.6.1 Connecting to DABin using DCM

Before sending or receiving any configuration file or the Web Site, you have to connect to DABin. DCM will prompt for the Administrator password before connecting.

To Connect to DABin follow these steps:

Select the DABin from the Devices List at the bottom of the DCM Window.

Select "Connect" from the "Devices" menu.

DCM will prompt for the administrator password. Enter the password or left the box blank if no password has been configured for DABin Administrator, then click on the "Ok" button.



NOTE

**DCM uses HTTP protocol for communication with DABin. Check for DCM configuration for a HTTP Proxy server if you cannot find a DABin or connect to it.**

## 5.6.2 Sending and Receiving Configuration

Once connected to a DABin you can receive current configuration or send any configuration **.dab** file to it.

**To Receive** Configuration from a connected DABin:

Select the command "Get from DABin..." from the "Configuration" menu.

The Get Configuration dialog box will appear starting transfer automatically.

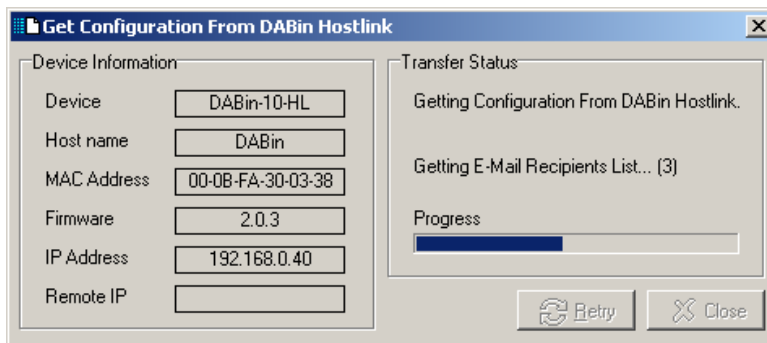

**Figure 55 - Receiving Configuration from DABin Hostlink**

When the transfer is complete click on the "Close" button. DCM will create a new configuration window with the just transferred configuration data.

**To Send** Configuration to a connected DABin:

Select the desired configuration window to transfer to DABin.

Select the command "Send to DABin..." from the "Configuration" menu.

The Send Configuration dialog box will appear showing the transfer status.

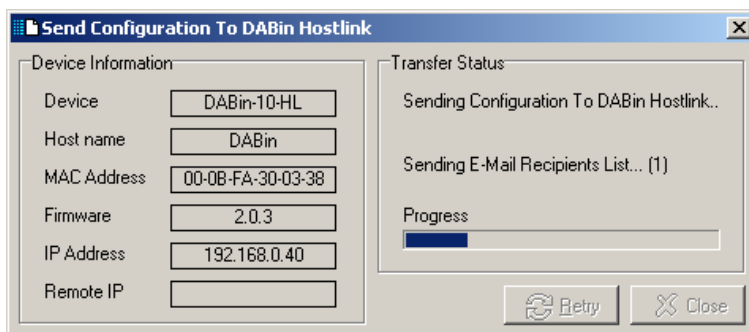

**Figure 56 - Sending Configuration to Connected Hostlink DABin**

# Chapter 6

## DABin DF1 Configuration

DABin DF1 works in Full-duplex mode, making queries to the DF1 PLC connected to its serial port about the value of each Tag configured and sending the write queries triggered from DABin's Web page or Tag Monitor in DCM. In this chapter we will give the details to configure DABin DF1 to achieve these functions.



NOTE

The present Chapter information refers to DABin DF1 Model only. DABin Serial Protocol is not configurable.

### 6.1 How DABin DF1 Works

DABin DF1 is based in Read cycles, Write cycles and acknowledges of Tag Alarms. Each cycle starts with a wait of the Scan Time period, configured by user, and then sends the pending write queries, sets the pending acknowledgments of Tag Alarms and Reads the rest of the Tags. In figure 57 is shown the complete Scan Cycle:

4. DABin waits for the Scan Time period: This time, configured by user, can be set from 0ms to 10000ms.

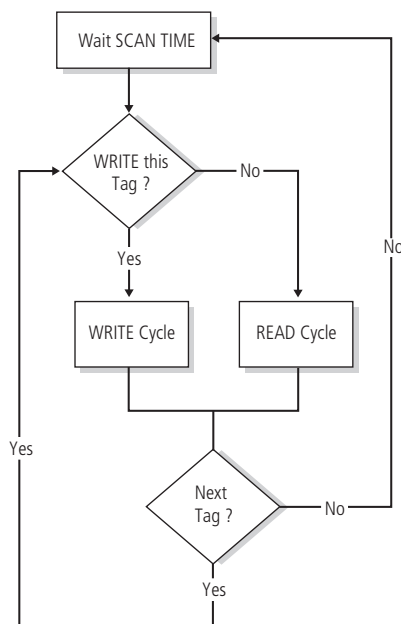

Figure 57 - Scan Cycle of DABin DF1

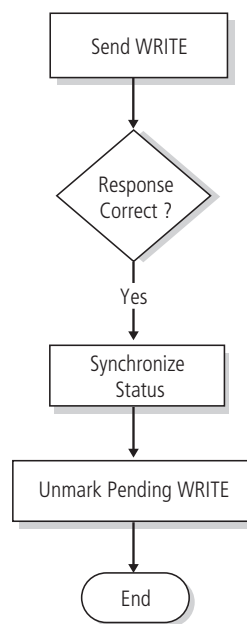
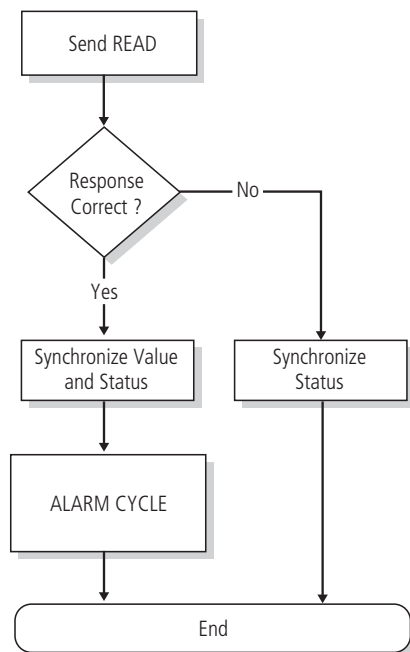

Figure 58 - Write Cycle of DABin DF1

5. Reads Tag configuration and verifies if there is a pending Write operation for this Tag. If this is the case, it starts a Write Cycle, if not it starts a Read Cycle. This procedure is repeated for each Tag.
6. When all Tags are done, it starts back to 1.

The **Write Cycle** is particularly simple and consists basically in sending the Write query, synchronize Tag Status, and unmark the pending Write so as not to repeat the writing in further cycles. Figure 58 shows the complete Write Cycle.

The **Read Cycle** is like the Write one, but it differs because it includes an Alarm Control Cycle. Once the reading of the Tag has been successfully done, it synchronizes the Tag Value and Status, and then starts an Alarm Control Cycle. The Read Cycle is shown in Figure 59.



**Figure 59 - Read Cycle of DABin DF1**

For DABin to start an Alarm Control Cycle for a Tag, this Tag must be Alarm-enabled in its configuration. If the Tag has its Alarm enabled, DABin maintains the Alarm Status for that Tag. Alarm Status can have any of the following values at a given time:

**In Alarm:** The Tag Value is in the Alarm condition, e.g. its value is in the defined Alarm range.

**Normal:** The Tag Value is not in the Alarm condition.

**Acknowledge:** The Tag Value is in the Alarm condition, but an operator has acknowledged this through a Web Browser.



NOTE

DABin only uses the *Protected typed logical read with three address fields* and *Protected typed logical write with three address fields* DF1 commands and it does not count on specific PLC information, such as processor or model. Many newer PLCs (such as FlexLogix and ControlLogix) do not provide, as a factory default, compatibility with the type of request issued by DABin. In Appendix A we show the mechanism to make these PLCs downwards-compatible with DABin.

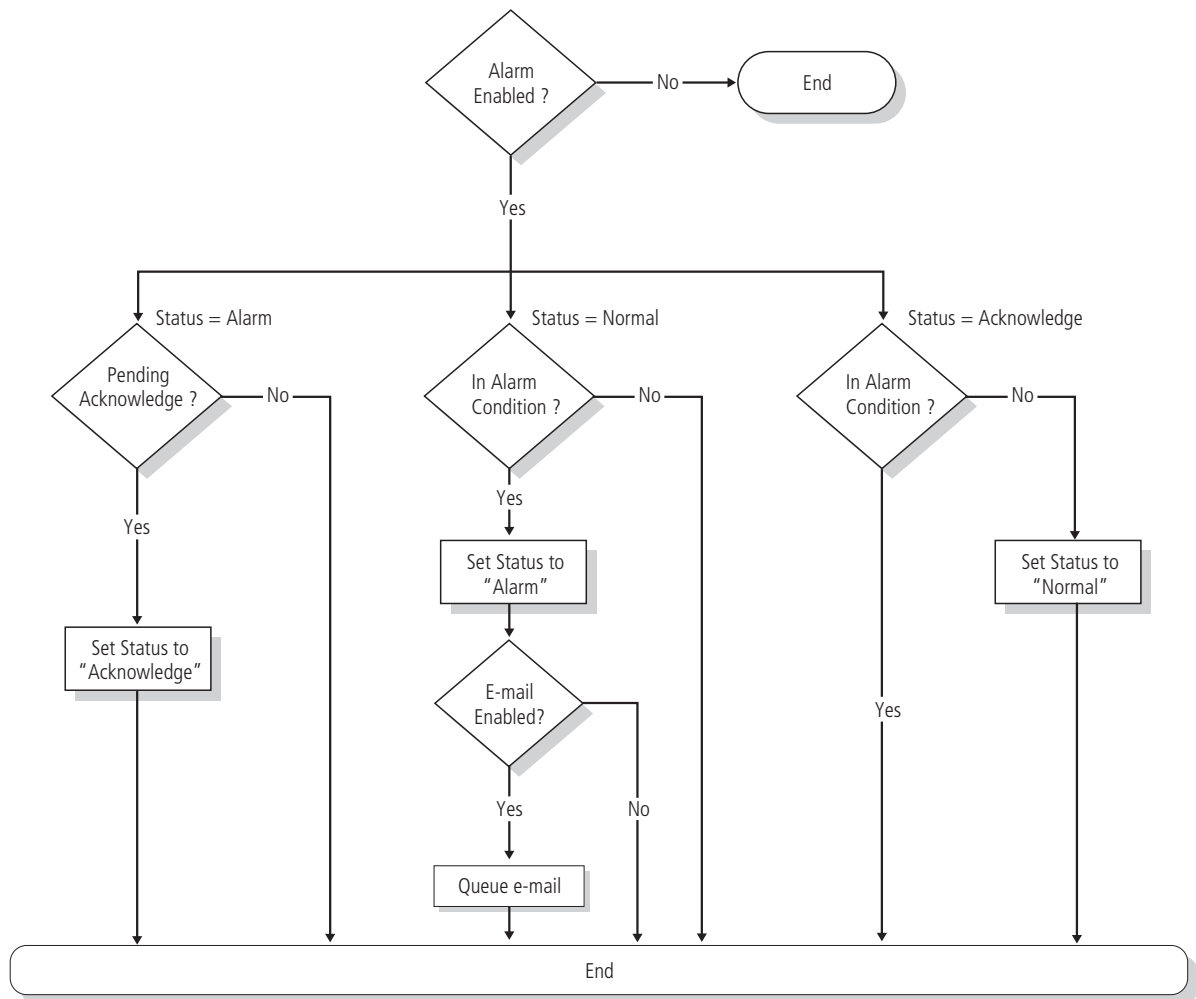

**Figure 60 - Alarm Control Cycle of DABin DF1**

Basically, Alarm Control Cycle is:

7. If Tag is in *Alarm* State, DABin verifies if an operator has acknowledged this. If this is the case, Tag Alarm State is changed to *Acknowledged* for the next Read Cycle of this Tag.
8. If Tag is in *Normal/Alarm* State, DABin verifies if the value is in the Alarm condition. If so, it changes its Alarm State to *Alarm* and an e-mail to the internal e-mails queue is added if Tag if e-mail enabled.
9. If Tag is in *Acknowledged* Alarm State, DABin verifies if the Tag value is in Alarm condition. If so, the Alarm State remains unchanged, if not the Alarm State is changed to *Normal*.



NOTE

**The total time DABin spends in reading all configured Tags will depend on the total count of Tags and Scan Time period. If any of the Tags is not properly configured, and DABin receives no response from the PLC after the maximum time (Timeout), this time will be added to the total time the Scan Cycle takes. Set the Timeout and Scan Time parameters with caution following the instructions in this Manual.**

## 6.2 Creating a DF1 Configuration File

DCM administrates DABin's configuration files with **.dab** extension. A configuration file can be created or downloaded from a DABin for modification or back up.



**Several configuration .dab files can be saved with different configuration and send any of them at any given moment. Then DABin will reset and start working with the new configuration in just seconds.**

- ▶ See also: "Sending and Receiving Configuration" on page 58

To create a new configuration file follow these steps:

Select command "New" from "File" menu. The New File dialog box will appear to select the new file type to create.

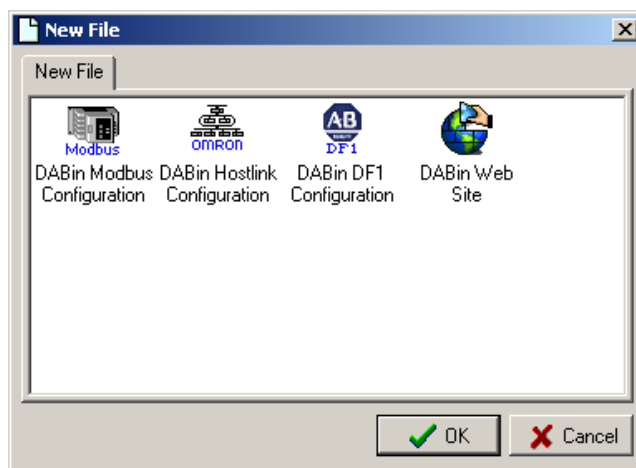

Figure 61 - New File dialog box

Select "DABin DF1 Configuration" from the list in the New File dialog box to create a new DF1 configuration file.

The new configuration file will be shown in the DCM Work area.



**When a file is modified but not yet saved, DCM will mark it with an asterisk (\*) besides the name of the file at the caption.**

## 6.3 Serial Port Configuration

In the case that DF1 Tags are going to be configured in DABin, the Serial Port must be configured correctly and coherently with configuration of the device connected to DABin's Serial Port.

The Serial Port parameters are:

**Com Type:** This parameter has effect only in DABin models where the Serial Port is configurable. RS-232, RS-485 or RS-422 can be selected.

**Baud Rate (bps):** Is the transmission and reception rate of the Serial Port. Any value in the range 2400bps to 115200bps can be selected.

**Parity:** Is the Serial Port Parity. Select either, None (No parity) or Even (Even parity).

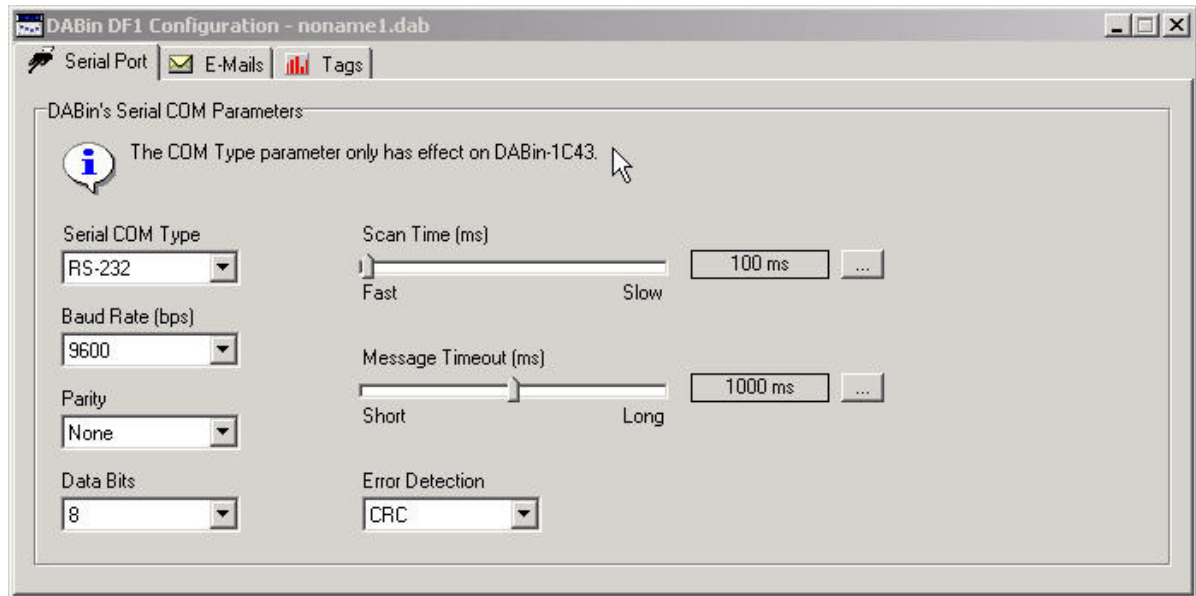

Figure 62 - Serial Port Configuration Page for DABin DF1

**Data Bits:** Select either 7 or 8 data bits.

**Scan Time:** Is the delay time in milliseconds DABin will wait before starting a new Scan Cycle.

**Maximum Response Timeout (*Message Timeout*):** Is the maximum time in milliseconds DABin will wait for a response from the slave.

**Error Detection:** Select the error detection method coherently with the PLC connected to DABin's Serial Port. Select either CRC or BCC.



NOTE

DABin DF1 supports only Full-duplex mode.



TIP

The Scan Time and Message Timeout parameters can be entered manually, clicking the "..." button besides the track bar.

## 6.4 E-Mail Configuration

DABin can send an e-mail when a Tag is in Alarm condition.

For this functionality to be available, all information to send e-mails must be given to DABin. Each time a Tag enters the Alarm condition with the Alarm e-mail enabled, DABin will queue a message to be sent as fast as possible.

DABin messages queue can save up to 128 alarms at the same time. If DABin couldn't send messages for a wrong configuration and the queue becomes full, DABin will not add more messages until a place appears in the queue.



**DABin empties the Alarm messages queue at startup or reset. Verify that all messages have been send before changing configuration or before resetting the device manually.**

DABin's internal e-mail sending machine retries sending a message a number of times after a given period if the e-mail couldn't be send in a given time. All these parameters are configurable in DABin.

If DABin couldn't send an e-mail, it can be configured to:

Erase the message from the queue after it has tried to send it the number of times configured.

Not to Erase the message and keep trying sending the message. This option can make a queue full if DABin is not correctly configured.

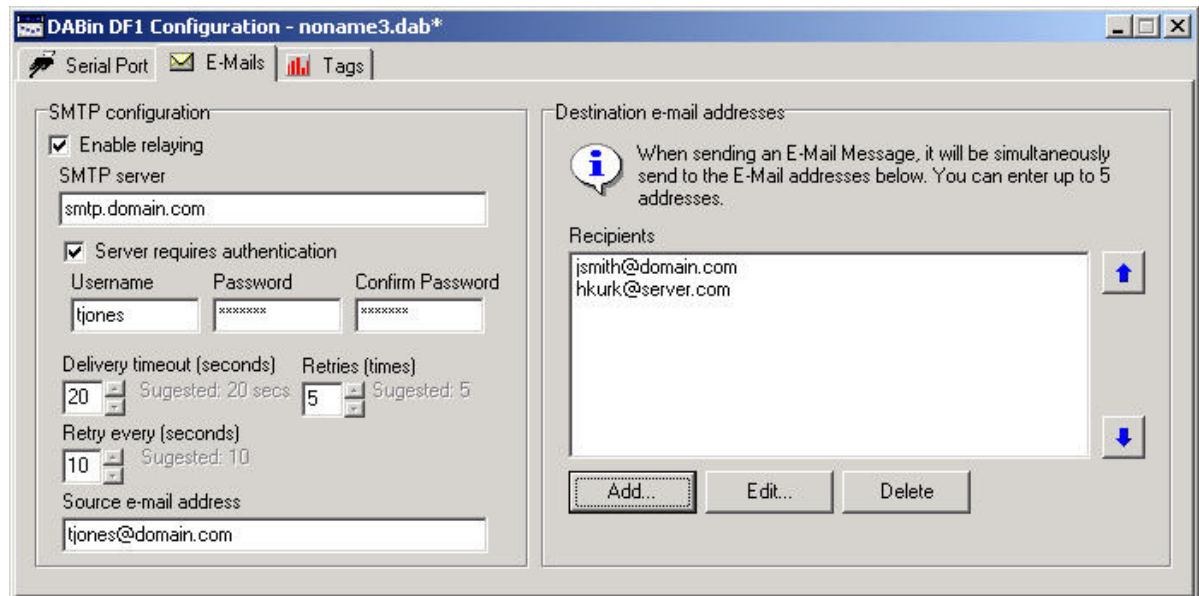

**Figure 63 - E-Mail configuration page of DABin DF1**

E-Mail configuration is composed of the following:

**Enable relaying:** Mark the check box to enable e-mail relaying service.

**SMTP server:** Name or IP Address of SMTP server.

**Server requires authentication:** Check this option if the SMTP server needs User+Password authentication (plain text authentication). (\*)

**Username:** Name required for user authentication.

**Password:** Secret key required for user authentication.

**Confirm Password:** Retype of the secret key.

**Delivery timeout:** This is the maximum lapse (in seconds) DABin attempts to send an e-mail.

**Retries:** How many times DABin will try to send an e-mail before removing it from the queue. If this parameter is 0, DABin will keep trying to send it without erasing the message from the queue.

**Retry every (seconds):** Delay between retries.

**Source e-mail address:** Source address used for outgoing e-mails.

**Destination e-mail addresses:** An e-mail can be delivered to up to 5 different destinations. Add a new destination by clicking on the "Add" button. The "Edit" button can be used to change an e-

mail address, while the "Delete" button removes one destination from the list. Change the relaying priority by rearranging the list using the arrows on the right side: DABin relays e-mail from top to down.

(\*) This feature applies to firmware version 2.1 and higher.

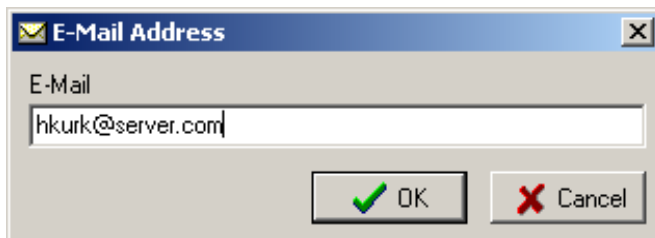

Figure 64 - E-Mail Address Edit Dialog box



For DABin to resolve the SMTP Server name correctly, at least one DNS IP Address must be properly configured. DABin will get the IP Address of the SMTP Server before sending e-mails. If no DNS Server IP Address is configured in DABin, SMTP Server IP Address must be entered explicitly. Ask your network administrator to obtain this information.

▶ See also: "Network Configuration Parameters" on page 22

## 6.5 Tags Configuration

DABin accept up to 128 different Tags. Tags can be:

**DF1 Tags:** These are the Tags DABin will ask the DF1 PLC connected to the Serial Port (RS-232/485/422). They must contain the information needed to access the value properly.

**DABin's Digital Inputs Tags:** Digital Tags whose value is the mirror of the current state of one of DABin's input. Its configuration must contain the number of Digital Input and is exclusively read-only.

**DABin's Digital Outputs Tags:** Digital Tags whose value is the mirror of the current state of one of DABin's output. The operator can change this value and this change will be reflected in the corresponding DABin Digital Output.

**Internal Tags:** Special Digital Tags that provide information of status of serial communication and general alarm of the rest of the Tags. Can be included or not.



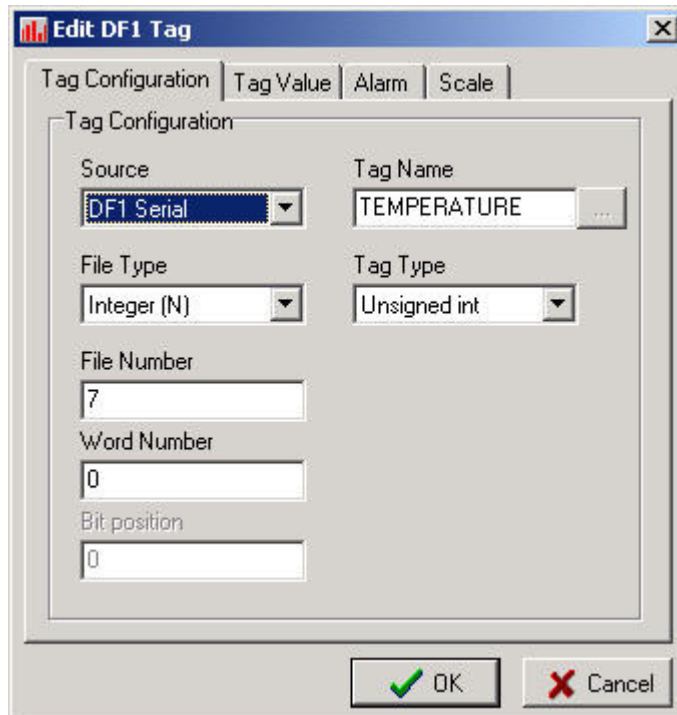

**Figure 66 - DF1 Tag Configuration**

To configure a DF1 Tag, enter the parameters described below:

**Source:** Select "DF1 Serial" to make a DF1 Tag. DABin will acquire the value from a PLC connected to its Serial Port.

**Tag Name:** Enter the Name of the Tag. DABin will identify this Tag with its Name.

**File Type:** Select the File Type of the Tag. Enter either Output (O), Input (I), Status (S), Binary (B) or Float (F).

**Tag Type:** Select the type of the Tag. Table 14 shows the file types supported by DABin.



NOTE

**If a Tag is any of the Integer types but an scaling function of the value is configured, DABin will convert the type of Tag to Float.**

**File Number:** Enter the File Number for the Tag. Remember that Tags in Files *Output*, *Input* and *Status* must be in File Number 0, 1 and 2 respectively. For File Types *Binary*, *Integer* and *Float* the File Number can be 3, 7 and 8 respectively or any File number greater or equal to 9 configured in the PLC.

**Word Number:** Is the Number of word (Address) for the register within the File.

**Bit Position:** Is the Bit number (position) for the "Word Bit" type. A value between 0 and 15 can be entered, when 0 is the least significant bit.

**Table 13 - Types of DF1 Tags and its representation**

Type	Description	Range
Unsigned int	16-bit Unsigned Integer	0..65535
Signed int	16-bit Signed Integer	-32768..32767
Long	32-bit Signed Integer	-2147483648..2147483647
Float	32-bit Float	-
BCD	16-bit BCD format	0000..9999
Word Bit	Bit in 16-bit Word	0, 1
Single Bit	Only for DABin's Digital I/O	0, 1

**Table 14 - File Types of DF1 Tags**

File Type	File Number
Output (O)	0
Input (I)	1
Status (S)	2
Binary (B)	3 or >= 9
Integer (N)	7 or >= 9
Float (F)	8 or >= 9

### 6.5.3 Notes on PLC reads and writes for inputs and outputs

Input and Output data can be both monitored or controlled. There are two choices for doing that,

- a- Ladder program copies useful data to an internal register, say, to the N table or B table and then N table or B table and access the data from there. Reading data from that location is straightforward. It is assumed that writes cannot be done in this approach.
- b- Reads and writes are directly performed to the connected inputs and outputs.

Let's focus our attention into choice b. The naming conventions used in the Allen-Bradley programming software are not supported by DABin Configuration Manager. To derive the correct address for each I/O point, first draw a schematic of the system. To address any given point, the word to select is given by the sum of the words occupied by previous modules of the same type (either Inputs or Outputs), regardless of the module's physical location. In other words, in order to address any particular point in the I/O datatable, one must know the number of words each module is consuming. Please notice that 8 point digital modules are considered as 1 word.

### 6.5.4 Digital Inputs and Outputs Tags

Tags related with DABin's Digital Inputs/Outputs can be defined. Digital Inputs and Digital Outputs are both enumerated from 0.

- ▶ See also: "Inputs and Outputs" on page 15



CAUTION

**The number of Digital Inputs and Outputs depends on the DABin Model. DABin will ignore Tags with Digital Inputs/Outputs that do not exist in the model in use.**

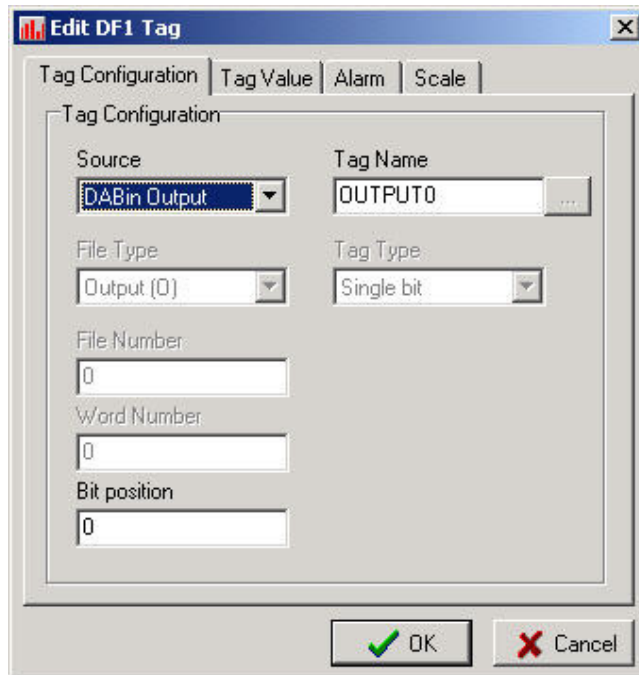

**Figure 67 - Digital Inputs / Output Tag Configuration**

To configure a Tag related with DABin's Digital Inputs / Outputs:

**Source:** Select "Digital Input" or "Digital Outputs" to relate the Tag with DABin's Digital Inputs/Outputs.

**Tag Name:** Enter the Name of the Tag. DABin will identify this Tag with its Name.

**Bit Position:** Is the Input / Output number. Enter a value in the 0 to 7 range. First Input is the 0 input, and so as with the Outputs.



NOTE

**DABin's Digital Inputs Tags must be declared as read-only.**

### 6.5.5 Internal Tags

DABin uses a set of internal Tags to give information about the general communication status and general Alarm status of the Tags. In Table 10 are listed all internal Tags supported by DABin.

**Table 15 - DABin Internal Tags**

Internal Tag	Description
_COMMERROR	Digital Tag. The value becomes 1 when a Serial Communication error is detected.
_ALARM	Digital Tag. The value becomes 1 when any Tag (Except Internal Tags) is in Alarm State, acknowledged or not
_ALARMNAK	Digital Tag. The value becomes 1 when any Tag (Except Internal Tags) is in Alarm State and has not been acknowledged by an operator.

To add an Internal Tag:

**Source:** Select "Internal" for the Tag to be updated by DABin internally.

**Tag Name:** Enter the name of the desired Internal Tag or click on the "... " button to see the Internal Tags lists. From the list select the Internal Tag and press "Ok".

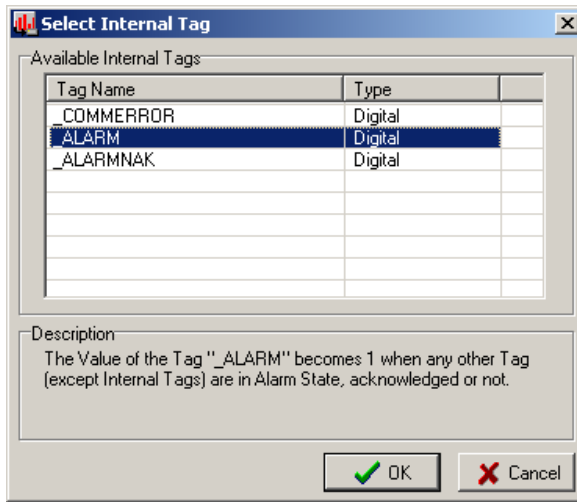

**Figure 68 - Internal Tag List**



TIP

**Enable Alarm and E-mail sending in Internal Tags to receive notification when DABin detects a failure in communication or any Tag enters the Alarm condition.**



NOTE

**All Internal Tags must be declared as read-only.**

### 6.5.6 Value Writing Restrictions

Tags in DABin can be configured as write-enabled in a given range of values or read-only. This can be done from the Value Configuration Page in the Configuration Tag dialog box.

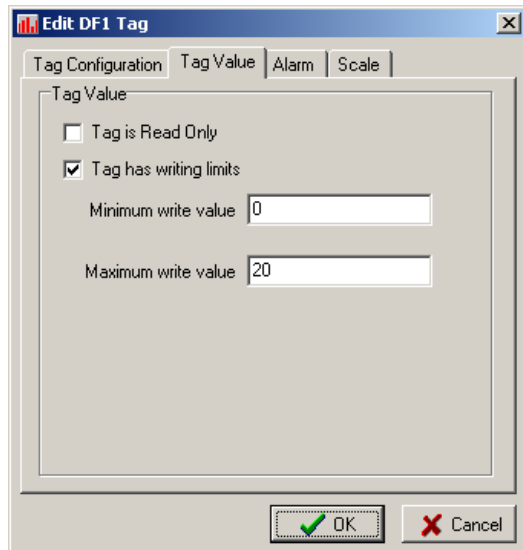

Figure 69 - Value Configuration Page

**Read only:** if the check box is marked DABin will not allow the operator to change the value of the Tag with a writing command from a Web browser.



NOTE

**The Tags representing DABin's Digital Outputs cannot be declared as Read Only.**

**Writing Limits:** marking the check box and entering the Minimum and Maximum values allowed for writing, DABin will allow an operator to write a value into this range.

### 6.5.7 Tag Alarm Configuration

To make DABin control the Alarm status of a Tag, the Tag must have its Alarm enabled.

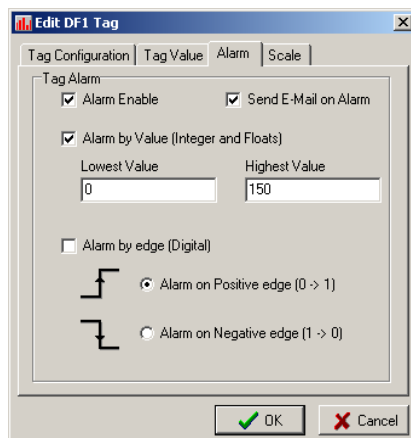

Figure 70 - Alarm Configuration Page

Alarms in DABin can be triggered by a range of values on analog Tags (Integers or Floats), or by detection of an edge in Digital Tags (Inputs/Outputs, Internal Tags or Word Bit).

**Alarm Enable:** To enable the Alarm for this Tag just mark the check box.

**Send E-Mail on Alarm:** If marked, DABin will queue an e-mail message when the Tag value enters the Alarm condition.

**If Tag is Analog** (Integer or Floating Point), mark the "Alarm by value" check box and then enter the Minimum and Maximum values for the Alarm. DABin will evaluate if the value is in that range after each Read Cycle, and if not the Alarm will be triggered.

**If Tag is Digital** (Inputs/Outputs, Internal Tags, Word Bit or Single Bit), mark the check box "Alarm by edge" and then select either, "Alarm on Positive edge" or "Alarm on Negative edge" as desired.

### 6.5.8 Tag Value Scaling

DABin can acquire a value and make a simple calculation before assign it to the Tag value. This is helpful for scaling factors and other simple calculation.

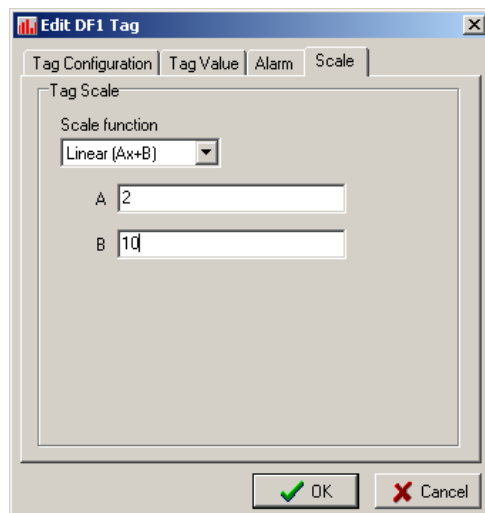

Figure 71 - Scale configuration page

DABin supports the Linear ( $Y=Ax+B$ ) function, where  $x$  is the acquired value and  $Y$  will be the Tag value. DCM allows to configure both A and B factors.



NOTE

#### Digital Tags are not scalable.

For the DABin to make the calculation on the acquired value select Linear ( $Ax+B$ ) as the scale function.

Enter values A and B. Floating point numbers can be entered for these factors.



NOTE

**If Tag has Minimum and Maximum writing limits and it is scaled, DABin will understand those limits as already scaled using the same factors and function, so as with the Alarm Limits. In general Writing Limits and Alarm Limits are referred to the Tag value and not the acquired value.**

## 6.6 Sending and Receiving Configuration

Once configuration is complete, you can save it in a **.dab** file and send it to DABin. Upon receiving the configuration, DABin will reset itself and start working with the new configuration. First connect to DABin using DCM and then transmit the new configuration or receive current DABin's configuration.

### 6.6.1 Connecting to DABin using DCM

Before sending or receiving any configuration file or the Web Site, you have to connect to DABin. DCM will prompt for the Administrator password before connecting.

To Connect to DABin follow these steps:

Select the DABin from the Devices List at the bottom of the DCM Window.

Select "Connect" from the "Devices" menu.

DCM will prompt for the administrator password. Enter the password or left the box blank if no password has been configured for DABin Administrator, then click on the "Ok" button.



NOTE

**DCM uses HTTP protocol for communication with DABin. Check for DCM configuration for a HTTP Proxy server if you cannot find a DABin or connect to it.**

### 6.6.2 Sending and Receiving Configuration

Once connected to a DABin you can receive current configuration or send any configuration **.dab** file to it.

**To Receive** Configuration from a connected DABin:

Select the command "Get from DABin..." from the "Configuration" menu.

The Get Configuration dialog box will appear starting transfer automatically.

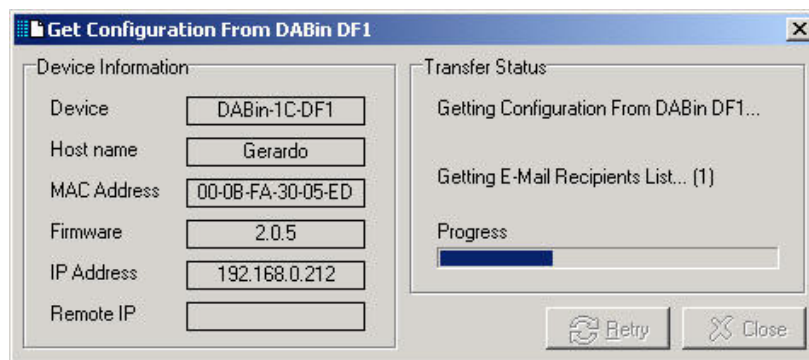

**Figure 72 - Receiving Configuration from DABin DF1**

When the transfer is complete click on the "Close" button. DCM will create a new configuration window with the just transferred configuration data.

**To Send** Configuration to a connected DABin:  
Select the desired configuration window to transfer to DABin.  
Select the command "Send to DABin..." from the "Configuration" menu.  
The Send Configuration dialog box will appear showing the transfer status.

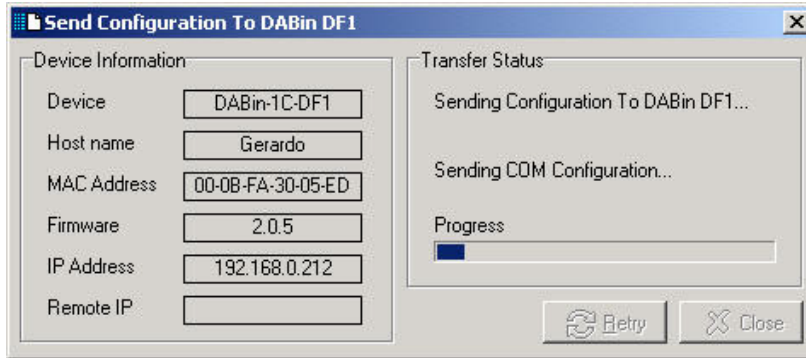

**Figure 73 - Sending Configuration to Connected DF1 DABin**

# Chapter 7

## Web Site Design

### 7.1 Introduction

DABin acquires information from the Real world and puts this information available to the user through its internal Web Server.

A complete Web Site can be designed and, transferred it to DABin. In this way you can show the acquired information in the most suitable form your solution requires.

#### 7.1.1 How a Web Site Works in DABin

DABin has an Internal Standard Web Server, so its Web Site does not differ from a conventional Web Site. The designer can use any standard Web page design software tool to develop a standard Web site and then transfer it to DABin.

DABin uses two methods to show the acquired information and to let the operator to change the Tag values:

**Java Applets:** These are small programs provided with DABin and ready to be inserted in a Web Page just the way you insert an image. This method lets the operator see the values in different formats (Bars, Numbers, Text, etc) and also change any of the values.

**SSI (Static Pages):** Using this method DABin replaces "marks" inside HTML code for a Tag Value, its Alarm State, etc, before sending the page to the Web Browser. So the operator sees a static Web Page, but with the values refreshed at the moment the page loaded in the Web Browser. Also the designer can put Links in static pages to change a value of a Digital Tag or to acknowledge an Alarm State.

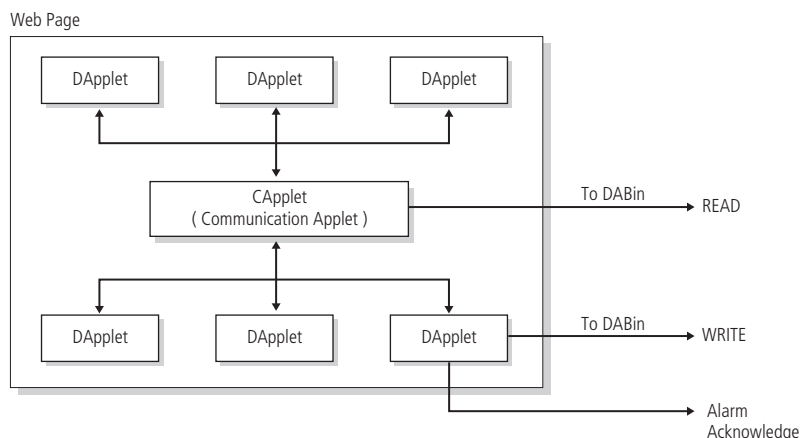

Figure 74 - DABin Web Page with Applets



TIP

**A page in DABin can contain Applets and SSI's simultaneously.**

DABin also has two kinds of Java Applets:

**DApplets:** are the applets that represent a Tag Value in different formats like Bars, Numbers, Text, Images, etc.

**CApplet:** Is the Applet that collects Tag information that DApplets must show and then queries DABin about all these Tag values at regular interval periods of time.

When a page includes at least one DApplet, a Communication Applet (CApplet) must exist.

When a page is loaded in the Web Browser, the DApplets in page send a message to the Communication Applet (CApplet) telling what Tag they must show.

The Communication Applet (CApplet) collects this information from all DApplets in page and asks DABin for the values of these Tags at regular periods of time.

Once the Communication Applet receives Tag values from DABin, verifies if some of them have changed its value, and if so, it sends the new value to the corresponding DApplets.

Write operations of Tag values are done by DApplets directly to DABin.

When a Tag value enters to Alarm State and the user acknowledges the state, the DApplet sends this information to DABin directly.



NOTE

**A Web page containing DApplets must include one CApplet to make the Read queries to DABin and refresh the values to the DApplets in the Page.**



CAUTION

**DABin's File System does not support folders. All files in a Web Site must be in the only "root" folder or directory.**

In Table 16 DABin's Web site characteristics supported are listed.

**Table 16 - DABin's Web Site characteristics**

Characteristic	Description
Maximum Web Site Size	1.5 Mbytes
Maximum Number of files in Web Site	128 Files
Maximum Number of Tags in DApplets in a Single Page	Unlimited, 45 Tags maximum recommended
Maximum filename length	Up to 17 characters long including extension

## 7.2 Applets Web page Design

### 7.2.1 Inserting an Applet in a Web Page

Depending on the software tool used for Web page design, this procedure may be different. All software tools create HTML code to be transferred to Web Server.

In this manual will give an HTML code approach, which is common to all Web page design software.

Listing 1 is a simple Web page with a CApplet inserted. The Applet is an object with properties, such as Program name (*.class*), Height, Width and others. Also the parameters passed to an Applet change its behavior. These parameters can be the Foreground color, the Tag name, etc.

#### Listing 1 - A Simple page with a CApplet inserted

```
<HTML><HEAD>
  <META HTTP-EQUIV="Content-Type" CONTENT="text/html; charset=windows-1252">
  <TITLE> Applet Test Page </TITLE>
</HEAD>
<BODY>
This is the Communication Applet (capplet)
<APPLET
  ARCHIVE   = "dabin.jar"
  CODEBASE  = "."
  CODE      = "capplet.class"
  WIDTH     = 25
  HEIGHT    = 25
  HSPACE    = 0
  VSPACE    = 0
  ALIGN     = middle
  >
<PARAM NAME = "SCANTIME" VALUE = "1000">
<PARAM NAME = "RUNMODE" VALUE = "RUN">
</APPLET></BODY></HTML>
```



NOTE

All DABin Applets are archived in a file named "dabin.jar". This file must be included in the Web site if any of the pages includes Applets.

### 7.2.2 The Communication Applet (CApplet)

For an Applets page to work, a Communication Applet (and only one) must be inserted.

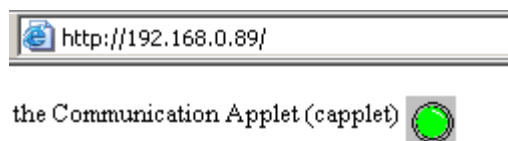

Figure 75 - The CApplet in a Web Browser

The CApplet accepts two parameters: SCANTIME is the time interval after the CApplet sends a Read query to DABin and refresh all DApplets in Page. RUNMODE indicates the CApplet the working mode.

Table 17 - Communication Applet Parameters

Parameter	Description	Values	Default Value
SCANTIME	Time between refreshes	500ms..10000ms	1000ms
RUNMODE	Working Mode for all Applets in Page	RUN: Default mode DEBUG: Shows information in Java Console TEST: No connection with DABin. For viewing purposes	RUN



NOTE



CAUTION

The SCANTIME parameter is not related with the Scan Time parameter in DABin's configuration. Its purpose is to give the refresh period of values in a Web Page.

The CApplet must be included only once in pages including DApplets. There must be a CApplet per Web Page. Remember that the CApplet refreshes the DApplets in the page that it is inserted.

### 7.2.3 The Data Applets (DApplets)

The Data Applets are called DApplets and are the Applets that represent the Tag Values in different ways.



Figure 76 - The Number Applet

All DApplets let writing a new value for the Tag, acknowledge its Alarm State and obtain general Status information about the Tag.

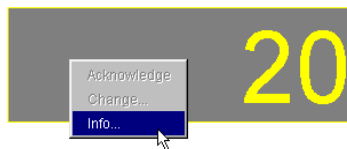

Figure 77 - Contextual Menu of DApplets

To have access to all this functionality, DApplets have a contextual menu with these options. To access the contextual menu Right-click with the mouse cursor over the DApplet and the contextual menu will appear as shows figure 79.

The menu options in all DApplets are:

**Acknowledge:** This option lets the user to acknowledge the Alarm State of a Tag, and will only be enabled in the case the Tag is in the Alarm State.

**Change:** With this menu option the Change value Dialog box will be displayed in order to write a new value for the Tag. If the Tag was configured in DABin as Read-only this option is disabled. If the Tag is analog (Integer or Float) the "Change" button in the dialog box will be enabled only if the entered value is in the valid writing range for that Tag. If the Tag is Digital, the "On" and "Off" buttons lets to activate or deactivate the bit value.

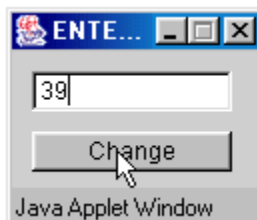

Figure 78 - Change Value dialog box



Figure 79 - Change value for Digital Tags

**Info:** When selecting this option from the contextual menu, the information Dialog box will appear with the status information of that Tag. In Tables 13 to 15 are listed the messages showed in the Information Dialog box and their Description.



**Figure 80 - Information Dialog box for a Dapplet**

**Table 18 - State Messages in the Information Dialog box**

State Message	Description
Unknown	Unknown State.
Idle	Register OK and Updated
Read	On reading
Write	On Writing
Read Error	Reading Error detected
Write Error	Writing Error detected
Read Initialization Error	Failure when trying to Read
Write Initialization Error	Failure when trying to Write

**Table 19 - Error Messages in Information Dialog box**

Error Message	Description
Unknown	Unknown Error
Ok	Register OK and Updated
Timeout	Timeout for response from slave
Syntax Error	Syntax error in Response from slave
Communication Error	Communication error detected
Exception	Exception detected
Invalid COM	Not a valid COM Port
Busy	The Com port is busy
Wrong Request	The Request is not valid
Invalid Address	The Address of the Request is not valid
Capplet not present	CApplet not present in Page
Unknown Tag	The Tag is unknown

**Table 20 - Alarm Messages in the Information Dialog box**

Alarm Message	Description
Ok	Normal, no alarm
Alarm	In Alarm state
Acknowledge	The Alarm was acknowledged

## 7.2.4 DApplets Parameters

All DApplets have a set of parameters in common, like the Tag Name they represent and the colors used in different states.

### Listing 2 - The Bar Applet with some Parameters

```
<HTML><HEAD>
  <META HTTP-EQUIV="Content-Type" CONTENT="text/html; charset=windows-1252">
  <TITLE> Applet Test Page </TITLE>
</HEAD>
<BODY>
<APPLET
  ARCHIVE = "dabin.jar"
  CODEBASE = ". "
  CODE = "bar.class"
  WIDTH = "12"
  HEIGHT = "64">
  <PARAM NAME="TAGNAME" VALUE="T1">
  <PARAM NAME="ORIENTATION" VALUE="UP">
  <PARAM NAME="MAX" VALUE="100">
  <PARAM NAME="MIN" VALUE="0">
  <PARAM NAME="COLOR_FG" VALUE="BLACK">
  <PARAM NAME="COLOR_BG" VALUE="WHITE">
  <PARAM NAME="COLOR_NO" VALUE="BLUE">
  <PARAM NAME="COLOR_NG" VALUE="BLUE">
  <PARAM NAME="COLOR_AL" VALUE="RED">
  <PARAM NAME="COLOR_AK" VALUE="YELLOW">
</APPLET>
</BODY></HTML>
```

In Table 16 are listed all parameters accepted by DApplets and their default value if omitted. Listing 2 is an example of a Bar Applet with some of these parameters.

**Table 21 - DApplets Common Parameters**

Parameter	Description	Values	Default Value
TAGNAME	Tag Name this DApplet will represent	Any Tag defined in DABin's configuration	NONAME
COLOR_FG	Foreground Color	(see table 17)	BLACK
COLOR_BG	Background Color	(see table 17)	WHITE
COLOR_NO	Color used when Tag is in Normal State	(see table 17)	GREEN
COLOR_NG	Color used when the Tag is in Normal State but its value is Negative	(see table 17)	BLUE
COLOR_AL	Color used when the Tag is in Alarm State	(see table 17)	RED
COLOR_AK	Color used when Tag Alarm is Acknowledged	(see table 17)	YELLOW

**Table 22 - Color Values**

Colors					
BLACK	CYAN	GRAY	YELLOW	ORANGE	RED
BLUE	DARKGRAY	GREEN	MAGENTA	PINK	WHITE

## 7.3 DApplets: The Basic Library

DABin provides a basic Library of DApplets. They can be used in DABin Web pages to show the Tag values in different formats.

### 7.3.1 The Number Applet: num.class

The Number Applet shows the Value of the Tag in a box like a display. The font and the number of Digits shown can be changed.



Figure 81 - The Number Applet

Table 23 - Number Applet Parameters

Parameter	Description	Values	Default Value
IDIGITS	Minimum Integer Digits	0..10	1
FDIGITS	Fractional Digits	0..10 or <b>D</b> to show all digits	D
FONT	Font of number	-	ARIAL

### 7.3.2 The Bar Applet: bar.class

The Bar Applet shows the value in bar with a filling color. Orientation, Minimum and Maximum values can be changed.



Figure 82 - The Bar Applet

Table 24 - Bar Applet Parameters

Parameter	Description	Values	Default Value
ORIENTATION	Bar orientation	UP, DOWN, RIGHT or LEFT	UP
MAX	Maximum value	Floating point value	100
MIN	Minimum value	Floating point value	0

### 7.3.3 The Image Applet: img.class

The Image Applet lets to show any image (like a .gif file) based on the value of the Tag. The image file must be included in the DABin's Web site.



Figure 83 - The Image Applet

**Table 25 - Image Applet Parameters**

Parameter	Description	Values	Default Value
IMAGE_ON	Image to be shown when Tag value is not 0 and it is not in Alarm State	Image File name	-
IMAGE_OF	Image to be shown when Tag value is 0 and it is not in Alarm State	Image File name	-
IMAGE_AL	Image to be shown when Tag value is in Alarm State	Image File name	-
IMAGE_AK	Image to be shown when Tag value is in Acknowledged State	Image File name	-

### 7.3.4 The Vectorial Applet: vec.class

The Vectorial Applet lets to show a specific image (not an image file) based on the value of the Tag. The type of image can be defined.

**Figure 84 - The Vectorial Applet****Table 26 - Vectorial Applet Parameters**

Parameter	Description	Values	Default Value
TYPE	Type of vectorial image	LED, PUMP	LED

### 7.3.5 The Text Applet: txt.class

The Text Applet shows a defined text when the Value of the Tag is in a given range. All the ranges and its alignment can be defined.

**Figure 85 - The Text Applet****Table 27 - Text Applet Parameters**

Parameter	Description	Values	Default Value
ALIGN	Alignment of the Text	0 – Left 1 – Center 2 – Right	0 (Left)
DATA <sub>n</sub>	Range and text to be shown in each case. For example: DATA0=0,10,LOW DATA1=11,100, HIGH	Min,Max,Text	-

## 7.4 Static Pages (SSI)

Static Pages can be designed in DABin without the need for Applets. In Static Pages all data is shown in a static way, so data is refreshed when the page is loaded in the Web Browser. The value of a Tag, its alarm state or a Text representing a value can be inserted in the HTML Code.

Also the designer can insert standard links in a Web page to change the value of a Digital Tag or to acknowledge an Alarm state.

### 7.4.1 Inserting a SSI in HTML Code

SSI's are HTML comments, so you can edit the HTML code manually to enter the comments or using your standard Web page design software.

The comments in HTML code have the format:

```
<!-- This is a comment -->
```

When a Web Browser asks DABin for a Web Page, DABin searches all comments in that page looking for a particular format comment. If it finds one, it replaces the comment with a value specified in the command inside the comment.



NOTE

**Web pages including SSI's comments must have the .shtml extension for DABin to search the commands in the inserted comments.**

#### Listing 3 - An SSI command

```
<HTML><HEAD>
  <META HTTP-EQUIV="Content-Type" CONTENT="text/html; charset=windows-1252">
  <TITLE> Applet Test Page </TITLE>
</HEAD>
<BODY>
The Value of the Tag named OUTPUT is: <!-- VALUE = OUTPUT, "%d"-->
</BODY></HTML>
```

Listing 3 is an example of a SSI command. If the file is named with .shtml extension, then DABin will replace all text between < and > (including these) with the value of the Tag at that moment, or an error message if a Tag with that name does not exist in DABin configuration.

### 7.4.2 The Tag Value in SSI

To insert the value of a Tag, use the VALUE command in a SSI. The format is:

```
<!-- VALUE = TagName, "FormatString" -->
```

**TagName:** Is the name of the Tag to be shown.

**FormatString:** Enter a format string for the value. After the "%" character is the formatting of the value like a "printf" function in the C programming language.

**Table 28 - Format specifiers for VALUE SSI Command**

Format	Description
%d	Decimal Integer
%u	Decimal unsigned Integer
%x	Hexadecimal Integer
%f	Float

For example this SSI Command will show the Tag Value with fixed size of 8 characters and filled with "0" at the left when necessary.

```
<!-- VALUE = TagName, "The Value is %08d" -->
```

### 7.4.3 The Alarm Value in SSI

To see the Alarm State of a Tag, the ALARM command can be used in SSI. The format for this command is:

```
<!-- ALARM = TagName, "OnText", "OffText", "AckText" -->
```

**TagName:** Is the name of the Tag.

**OnText:** The text DABin will replace the complete comment with if the Tag is in Alarm State.

**OffText:** The text DABin will replace the complete comment with if Tag is in Normal State.

**AckText:** The text DABin will replace the complete comment with if Tag is acknowledged.



**Any Text can be an Image File name, so the Web Browser will put the image when DABin replaces the comment with the Text.**

For Example, this SSI command will show three different Images depending on the Alarm State:

```
<!-- ALARM = TagName, "inalarm.gif", "normal.gif", "ack.gif" -->
```

### 7.4.4 The Text by Value in SSI

DABin can replace the SSI with a Text depending if the value of the Tag is in a given range or in a given value. There are two SSI commands for this purpose, one for Digital Tags (DTEXT) and the other for Analog Tags (ATEXT). The formats of both of them are as follows:

```
<!-- DTEXT = TagName, "OnText", "OffText" -->
```

```
<!-- ATEXT = TagName, StartValue, EndValue, "InText", "OutText" -->
```

**TagName:** Is the Value of the Tag.

**OnText:** Text DABin will replace the complete comment with if Digital Tag is ON (1).

**OffText:** Text DABin will replace the complete comment with if Digital Tag is OFF (0).

**StartValue:** Starting value of the Range.

**EndValue:** Ending Value of the Range.

**InText:** Text DABin will replace the comment with if Value is in the specified range.

**OutText:** Text DABin will replace the comment with if Value is out the specified range.



TIP

To specify an arbitrary number of ranges insert ATEXT commands one after the other.

For example, this SSI command will show the Text "Turned ON" if the Digital Tag INPUT has a value of 1.

```
<!-- DTEXT = INPUT, "Turned ON", "Turned OFF" -->
```

#### 7.4.5 Execute Links in SSI pages

A link is a reference to other page or a server program in HTML pages. The user can click on a link to go to another page or to execute a program resident in the Web server.

DABin incorporates an internal CGI program called "execute.cgi" that can be called in order to change a Digital Tag value or to acknowledge an Alarm Tag state.

##### Listing 4 - Standard Link Example

```
<HTML><HEAD>
<TITLE>Link Example</TITLE>
</HEAD>
<BODY>
  <P><A HREF="values.shtml">Click here to see the Values page</A></P>
</BODY></HTML>
```

Listing 4 is an example of a standard link. The <A> and </A> tags define the link. The command HREF defines the target of the link.

A call to a CGI program resident in the Web server can be done using a link. The parameters passed to the CGI can be included in the link target. This is called an HTTP GET method.

##### Listing 5 - CGI call using the HTTP GET Method

```
<HTML><HEAD>
<TITLE>Execute Example</TITLE>
</HEAD>
<BODY>
  <P><A HREF="execute.cgi?command=set&tag=TAGNAME">Set TAGNAME to 1</A></P>
</BODY></HTML>
```

As shown in listing 5, the target of the link is a special format string. The general syntax for this string is as follows:

```
execute.cgi?command=CMD&tag=TAGNAME
```

First there's the name of the program "execute.cgi". It follows a "?" that indicates the start of the parameters passed to this program. Then there are the parameters in the format "Field=Value" and separated each other with the "&" character. The "execute.cgi" program accepts only two parameters: *command* and *tag*. The command value can be either "set" to change a digital Tag value to 1, "reset" to reset a digital Tag value to 0 or "ack" to acknowledge an Alarm state of a Tag. The tag field must contain the name of the Tag for which the operation is to be performed.

To SET a Digital Tag value to 1 enter a link in the HTML code as follows:

```
<A HREF="execute.cgi?command=set&tag=TAGNAME">Text in Link</A>
```

To RESET a Digital Tag value to 0 enter a link in the HTML code as follows:

```
<A HREF="execute.cgi?command=reset&tag=TAGNAME">Text in Link</A>
```

To Acknowledge an Alarm State in a Tag enter a link in the HTML code as follows

```
<A HREF="execute.cgi?command=ack&tag=TAGNAME">Text in Link</A>
```

DABin's internal Web server will execute the "execute.cgi" script, which will interpret the command and take the corresponding action when the user clicks on the link.



CAUTION

**No spaces are accepted in the HREF command of the link. The Web Server will not interpret the command correctly if spaces are inserted in the GET Method string.**

## 7.5 Creating the Web site file

Once all necessary Web pages are done you have to create a Web site file before uploading them to DABin. A Web Site file is an archive, which includes all files in the Web Site. Using DCM you can add files to this archive, remove files or extract a file resident in the archive.

DCM administrates DABin's Web Sites files with **.xms** extension. A Web site file can be easily created or downloaded from a DABin for its modification or backup.



TIP

**Several Web Site .xms files can be saved with different Web pages in it, sending any of them at any given moment. Once the Web Site transfer has finished DABin's Web Server will serve the new pages.**

- ▶ See also: "Transferring the Web Site" on page 88

To create a new Web Site file follow these steps:

Select command "New" from the "File" menu. The New File dialog box will appear to select the new file type to create.

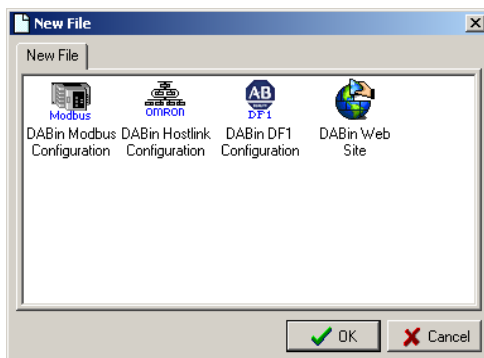

**Figure 86 - New File dialog box**

Select "DABin Web Site" from the list in the New File dialog box to create a new Web Site File.

The new Web site file will be shown in the DCM Work area.



**When a file is modified but not yet saved, DCM will mark it with an asterisk (\*) besides the name of the file at the caption.**

### 7.5.1 Administration of files in a Web Site Archive

With a DABin Web Site window opened, you can Add, Remove or Extract the files within the .xms file. Remember that no folders can be created in a Web site, so all added files are added in "root" folder or directory.

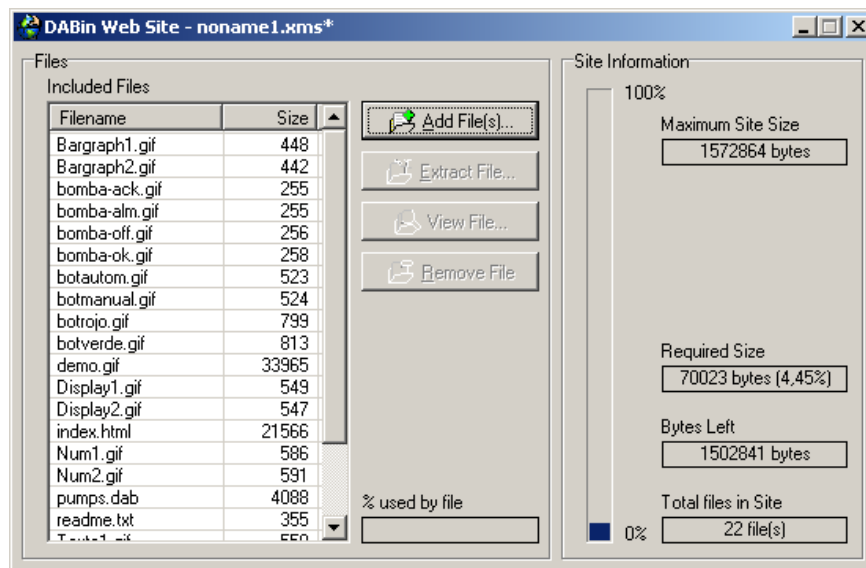

Figure 87 - Web Site Window in DCM

**To Add a File to Web Site:** Click on the "Add File(s)..." button. The "Select Files" dialog box will appear. Select one file or multiple files to add and click the "Open" button. All selected files will be added to the Web Site.

**To Extract a File from the Web Site:** Select the desired file from the list and click the "Extract File" button. The "Save as" dialog box will appear. DCM will save the selected file with the given name.

**To View a File:** Select the desired file from the list and click the "View File" button. DCM will open a window showing the file content. The File Viewer is intended to be used in raw ASCII files, like HTML files. If you select a binary content file you will not be able to see all the file content.

**To Remove a File from the Web Site:** Select the desired file from the list and click the "Remove File" button. A confirmation dialog box will appear. Answer "yes" if you are sure to remove the file from the Web Site.

### 7.5.2 Transferring the Web Site

DABin incorporates an internal FTP Server for Web Site transferring. The easiest way to transfer the Web Site is using DCM, but you can also use any standard FTP Client.

To do transfers of Web Site from or to DABin using DCM follow these steps:

Search for DABin in the network and connect to it.

- ▶ See Also: "Connecting to DABin using DCM" on page 44

Create a new Web Site file and add all the necessary files to it, or open an existent .xms file.

**To send the Web Site:** Select "Send to DABin" command from the "Web Site" menu. The Transfer window will appear starting the transfer. You can cancel the transfer at any moment clicking the "Cancel" button.

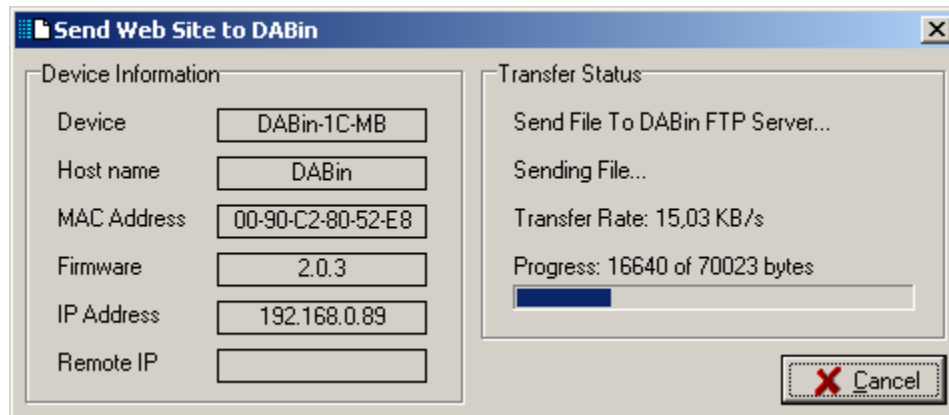

Figure 88 - FTP Transfer in DCM



CAUTION

If you cancel the transfer of the Web Site or the transfer is interrupted for any reason, then the Web Site will be corrupted in DABin. You will have to retransfer the entire Web Site again.

**To get the current Web Site from DABin:** Select "Get from DABin" from the "Web Site" menu. The Transfer window will appear starting the transfer. DCM will open a new Web Site file with the downloaded archive, so you can save it, modify it or send to another DABin in the network.

### 7.5.3 Using a Standard FTP Client

For the Web Site transfer you can use any standard FTP client application program since DABin's FTP Server acts as any standard FTP Server.

DABin's File System recognizes a unique file named "userpage.xms" (case sensitive). This file corresponds to the Web site files in a xms file. When uploading a file through a standard FTP client you will have to rename your Web site file to "userpage.xms".

To upload or download the Web site file using a standard FTP Client follow these steps:

Connect to DABin's FTP Server as you do to any FTP server.

Login to DABin's FTP server using the standard user or the "anonymous" user for read-only, or the "admin" user for read / write permissions.

- ▶ See Also: "DABin's Security Scheme" on page 27

You can download the "userpage.xms" file using your FTP client, and then open this file with DCM to modify it.

#### Listing 6 - Getting the Web Site file using the FTP.EXE

```
ftp> open 192.168.0.89
Connected to 192.168.0.89.
220 Welcome to Exemys FTP Server
```

```
User (192.168.0.89:(none)): admin
331 Password required
Password:
230 User logged in.
ftp> dir
200 PORT command successful
150 Opening ASCII mode data connection for /bin/ls
-rw-rw-rw-  1 1225  1225  112542 Jan 01 08:52 userpage.xmls
226 Transfer complete.
71 bytes received in 0.00 seconds (71000.00 Kbytes/sec)
ftp> get userpage.xmls
200 PORT command successful
150 Opening BINARY mode data connection (112542 bytes)
226 Transfer complete.
112542 bytes received in 5.55 seconds (20.28 Kbytes/sec)
ftp>
```

To upload a Web site file, rename your Web Site file created with DCM to "userpage.xmls" and then upload it using your standard FTP client.

#### Listing 7 - Sending a Web Site file to DABin's FTP Server usign FTP.EXE

```
ftp> open 192.168.0.89
Connected to 192.168.0.89.
220 Welcome to Exemys FTP Server
User (192.168.0.89:(none)): admin
331 Password required
Password:
230 User logged in.
ftp> dir
200 PORT command successful
150 Opening ASCII mode data connection for /bin/ls
-rw-rw-rw-  1 1225  1225  169 Jan 01 08:52 userpage.xmls
226 Transfer complete.
68 bytes received in 0.00 seconds (68000.00 Kbytes/sec)
ftp> put
(local-file) c:\DABin\Control\control.xmls
(remote-file) userpage.xmls
200 PORT command successful
150 Opening BINARY mode data connection.
226 Transfer OK. Got 136436 bytes
136436 bytes sent in 20.16 seconds (6.77 Kbytes/sec)
ftp> dir
200 PORT command successful
150 Opening ASCII mode data connection for /bin/ls
-rw-rw-rw-  1 1225  1225  136436 Jan 01 08:52 userpage.xmls
226 Transfer complete.
71 bytes received in 0.00 seconds (71000.00 Kbytes/sec)
ftp>
```

# Chapter 8

## Tools

### 8.1 The DCM Tag Monitor

Once Tags are created and sent to DABin, it is not necessary to create a Web page to see how the created Tags work.

The DCM ships with a Tool called Tag Monitor that simulates an Applet behavior, so you can test all the Tags without the need to create a Web Page.

The Tag Monitor lets the user to write values to Tags and acknowledge Alarms, see the current Tag value, a graphical history of the last seconds of the value and the state of the DABin's e-mail sending machine.

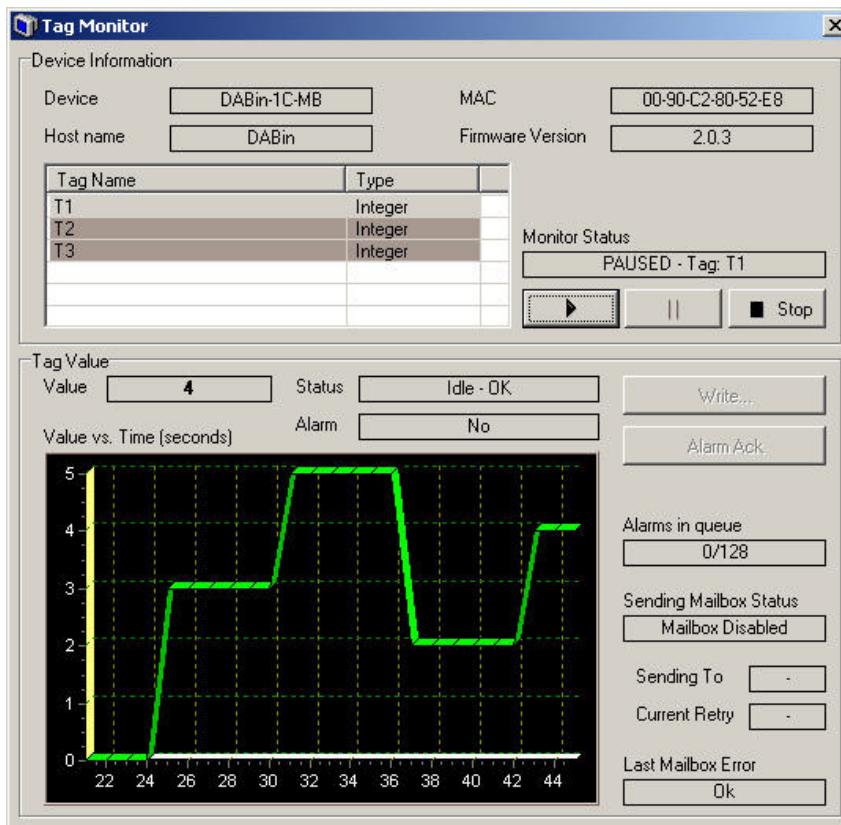

Figure 89 - DCM Tag Monitor

When connected to DABin select "Tag Monitor" from the Tools menu. DCM will start scanning all configured Tags in DABin. Then the Tag Monitor dialog box appears.

At the Top of the Tag Monitor dialog box there's a listing of all available Tags. At the bottom there's the status information when monitoring a Tag.

To monitor a Tag activity follow these steps:

Select the Tag from the list and click the "Play" button (the one with the right arrow). The monitor will start.

To write a value to the Tag click the "Write..." button. The Write value dialog box will appear. Enter the desired value and click "Ok".

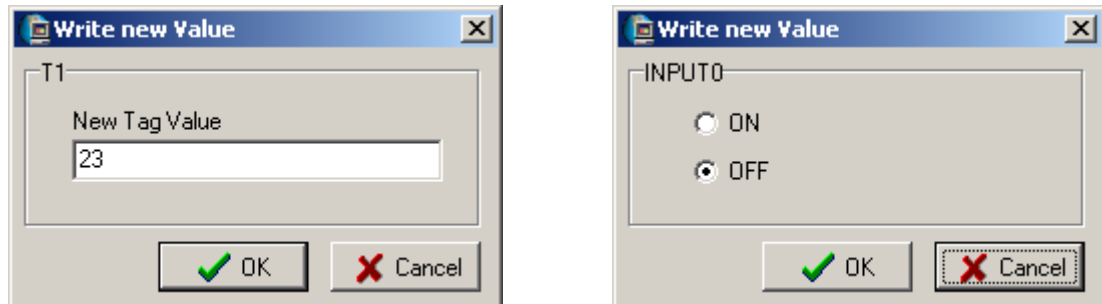

Figure 90 - Tag Write dialog box for Tag Monitor

The value, the graphic and the Alarm status will be in Red color if it is in Alarm State. You can click the "Alarm Ack" button to acknowledge the Alarm. When acknowledged the color changes to Blue.

To Pause the monitoring click on the Pause button. To resume click the Play button again or click the Stop button to stop monitoring.

Once monitoring is stopped, you can click the "Close" button to close the Tag Monitor dialog box.



NOTE

**For analog Tags (Integers and Floats) the graphical history scales automatically depending the values shown. For Digital Tags, the graphical history scale is fixed to show the 1 and 0 values only.**

To select another Tag, stop the Tag monitoring, select another Tag from the list and click the Play button to resume.

## 8.2 Serial Commands Console

The DABin's Serial commands Console consists in a commands console that can be executed attaching a serial crossover cable to DABin's RS-232 port.

The console provides commands for administration password change, reset configuration to factory default and see current firmware version and serial number.

To execute the serial command console just connect a serial crossover cable to DABin's RS-232 port to a PC as shown in figure 5 (chapter 2) and follow these steps:

Connect the serial cable to DABin's RS-232 port and to the PC serial Port.

Open a Terminal application program like HyperTerminal or the like and configure the serial port as **9600 bps, Parity None, 8 Data bits and 1 Stop bit, without flow control (9600N81)**.

Recycle DABin power and when turned on enter "cfg" in the terminal within the first 7 seconds during DABin initialization. (Yellow led blinks slowly during these first 7 seconds). The Welcome message will appear following a prompt that indicates DABin waits for a command to be executed.

#### Listing 8 - Welcome message to the DABin Serial Commands Console

```
DABin Console
-----
>
```

### 8.2.1 Resetting configuration to factory defaults

For resetting configuration to the factory defaults you can use the **factreset** command. The command must be typed twice for confirmation and no parameters are expected.

#### Listing 9 - Using the factreset command to reset configuration to Factory defaults

```
>factreset
Type command again to reset to Defaults

>factreset
Reset to Defaults
```



CAUTION

**When configuration has been reset to factory default all previous configuration in DABin is lost.**

DABin will reset and start with the default configuration.

### 8.2.2 Changing the Administrator password

To change the administrator password without the need for the previous password you can use the **password** command in DABin's Commands Console. The command has the syntax as follows:

**password:***newpassword*

You cannot disable the administrator password with this command. If you want to disable it, enter any password and then disable the password using the DCM application program.

#### Listing 10 - Using the password command

```
>password:mypass
Password Changed
```

### 8.2.3 Seeing the firmware version and ending the commands console

To see current firmware version enter the **ver** command. This command will show you the current firmware version in the format X.X.X, the MAC address or Serial Number and a program CRC to verify the firmware is correct.

#### Listing 11 - Using the ver command to see the current firmware version

```
>ver
Version: 2.0.3
Mac: 00-90-C2-80-52-E8
Calculating CRC...
CRC: EE96
```

To finish the Serial commands Console and let DABin to start polling the configured Tags, use the **end** command.

**Listing 12 - Using the end command to finish the Commands Console**

```
>end  
Session Ended
```

When the end command is executed, DABin will change its mode to Scanning mode, closing the commands console and starting polling all the Tags configured. You can also recycle DABin power instead of entering the end command for DABin to start the Scanning mode.



**If you don't enter the end command or recycle power when finished using the Commands Console, DABin will not start polling the Tags.**

# Appendix **A**

## **A. Command set downward compatibility in newer Allen-Bradley PLCs**

Time ago, Allen Bradley came out with some modifications about the way that newer PLCs exchange data. In the new approach, the PLC defines tags to map data, rather than Files. At the moment of this publication, those PLCs belong to the FlexLogix and ControlLogix family. The new commands are not compatible with DABin, yet. However, AB provides downwards-compatibility with the old command set. Recall that DABin only uses the *Protected typed logical read with three address fields* and *Protected typed logical write with three address fields* DF1 commands and it does not count on specific PLC information, such as processor, model or firmware version. Here we provide some basic information to activate the downward compatibility feature with RSLogix 5000.

To map an address:

1. In RSLogix 5000 software, open the project file for the controller whose data you want to access
2. From the Logic menu, select Map PLC/SLC Messages
3. The screen shown will be used to provide the actual mapping between an already defined tag and the File Number you choose to make public to DABin. Complete the information required as an SLC mapping. (Choose an appropriate File Number). The tags must be controller-scoped (global).
4. Click OK



NOTE

**If you want to map many data into one File, you can define a tag as an array.**

# Appendix B

## B.Data Logging

---

### B.1. Introduction

---

There's a special version of DABin called DABin-R that features data logging capabilities. It's able to log up to 16 tags at fixed periods of time.

It has a 512 Bytes memory to store the logged tags. Its autonomy depends on how many tags are being logged and how often they are stored. Once the memory is full old data will be overwritten.

If you log 16 tags 7710 registers will fill up the memory. If you log only one tag DABin-R will store 65536 before start overwriting the old registers.

The formula to calculate how many register will fill up the memory is the following:

$$\text{Registers} = 524.288 / (4 + 4 \times \text{tag quantity})$$

Example:

Tags to log:2, Sampling time: 10 minutes

$$\text{Registers} = 524.288 / (4 + 4 \times 2) = 43.690 \text{ registers}$$

$$\text{Autonomy} = 43.690 \times 10 \text{ minutes} = 436.900 \text{ minutes} = 303 \text{ days}$$

### B.2. Configuration

---

DCM software allows you to enable and configure this feature.

If you are configuring a DABin-R you will find a new tab named "Log" on the device properties window.

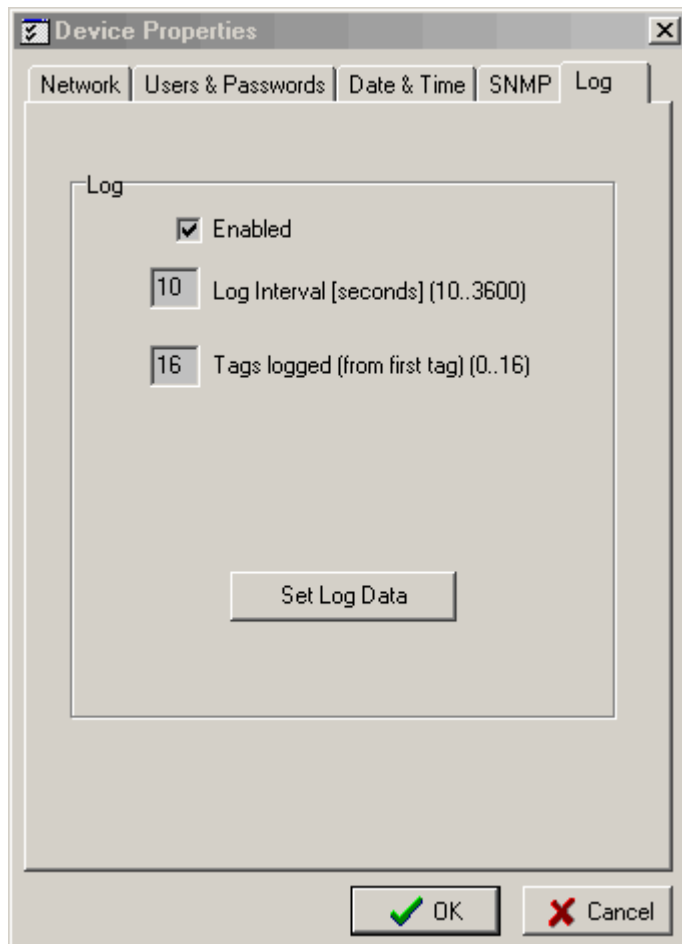

**Figure 91 – DABin-R configuration on DCM**

To enable the data logging feature tick the "Enable" check box. Then configure how often you want to create a new record on the "Log Interval" text box. Finally configure how many (N) tags you want to include in each record on the "Tags Logged" text box. DABin-R will log the first N configured tags.

Press the "Set Log Data" button to store the data logging configuration on the DABin-R.

Note 1: Modifying the "Tags Logged" will clear the log memory.

Note 2: Configure the DABin-R as shown in 3.4 before start logging data to have the right time stamp on each record.

### B.3. Reading the logged data

---

To read the logged data you have to use the DABin's web server. Inside the server there is a CGI application (Common Gateway Interface) that processes requested data to show it to the user.

There are three available formats to access the logged data. 1) As an attached CSV file (Comma-separated values) . 2) Direct CSV file that can be easily used by a JavaScript code. 3) As an HTML table.

The CGI application will process the data depending on the parameters sent on the http query string (GET mode). It will wait for begin and end time, output format (attached or not).

Query format:

```
http://dabin_url/log.cgi?since=begin_time&to=end_time&output=format&decimal=decimals_number
```

Where:

- *dabin\_url* is the DABin's name or IP address.
- *begin\_time* is the oldest time of the record you want to download
- *end\_time* is the newest time of the record you want to download

Time Format: *ddmmyyyhhmmss*

dd    day  
mm    month  
YYYY year  
hh    hour (24 hours format)  
mm    minutes  
ss    seconds

- *format* Output format to show logged data

Output Format:

csv	Attached CSV file
view	Direct CSV file
table	HTML table

- *decimals\_number* Indicates how many digits will be shown after the decimal point on float or scaled tags. This field is optional. Its default value is 3.

This is a query example to get data from the whole 2009 year and show it as a CSV file.

```
http://192.168.0.100/log.cgi?since=01012009000000&to=31122009235959&output=csv
```

After sending this query your web browser will ask you where you want to store the downloaded file. The file's name will have the DABin's name and begin/end time on it.

If the queried period doesn't include records the downloaded file will be empty.

The CSV file can be open by Microsoft Office, Sun Open Office, Google Docs, etc. It's an ASCII file where the values are separated by commas and each record ends with a carriage return (CR)

If you configure the DABin-R to log more tags than the configured tags you'll see '*undef*' on its value on the CSV file.

#### **B.4. SSI with log status**

---

If you want to see the status of the log you can use an SSI (Server Side Include) that will give you this information. This SSI must be included in an SHTML file as described on 7.4.

```
<!--LOGDATA-->
```

This will return these values that can be used by JS to show the status to the user.

1. Log status (RUN or STOP)
2. Records stored on the memory
3. Oldest stored records (same syntax as in log.cgi)
4. Newest stored records (same syntax as in log.cgi)

#### **B.5. Example**

---

On the CD provided together with the DABin-R you will find HTML code that will help you to create a web page to download the logged records.

The first example uses SSI to show the log status.

The second one uses CGI to download the records on different formats. It uses JS code to display a calendar to select the first and last records time.

Choose begin and end time	
Begin:(dd/mm/yyyy hh:mm:ss)	End:(dd/mm/yyyy hh:mm:ss)
18-08-2009 17:19:02	

- Download CSV file:
- View CSV files:
- View HTML table:

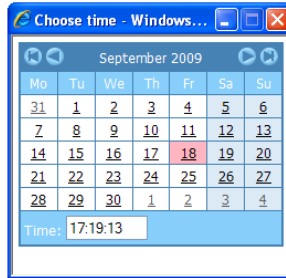

This is how you will see something like this if you select the "HTML Table" format.

Time	Tag 1	Tag 2	Tag 3	Tag 4	Tag 5	Tag 6	Tag 7	Tag 8	Tag 9	Tag 10	Tag 11	Tag 12	Tag 13	Tag 14	Tag 15	Tag 16
30/08/05 12:17:00	-32257	0	0	0	0	0	0	0	0	0	0	0	0	undef	undef	undef
30/08/05 12:17:10	19455	19455	19455	19455	19455	19455	19455	0	0	0	0	0	0	undef	undef	undef
30/08/05 12:17:20	19455	19455	19455	19455	19455	19455	19455	19455	19455	19455	19455	19455	0	undef	undef	undef
30/08/05 12:17:50	0	0	0	0	0	0	0	0	0	0	0	0	0	undef	undef	undef
30/08/05 12:18:00	0	0	0	0	0	0	0	0	0	0	0	0	0	undef	undef	undef
30/08/05 12:18:10	0	0	0	0	0	0	0	0	0	0	0	0	0	undef	undef	undef
30/08/05 12:18:20	0	0	0	0	0	0	0	0	0	0	0	0	0	undef	undef	undef